



KIRKEY

RACING FABRICATION

WWW.KIRKEYRACING.COM

Racing Seats

2009 CATALOG

*25
years*



KIRKEY

Professional Aluminum

Racing Seats

what do you race?

<u>Asphalt Late Models</u>	<u>2, 4</u>
<u>Asphalt Modified</u>	<u>2, 4</u>
<u>Dirt Late Models</u>	<u>4, 5, 6, 7</u>
<u>D.I.R.T. Modified</u>	<u>7, 12, 14</u>
<u>IMCA</u>	<u>4, 5, 6, 7</u>
<u>Trucks</u>	<u>2, 7</u>
<u>Modified Lights, Dwarf Car</u>	<u>10</u>
<u>Street Stock</u>	<u>7, 8, 9</u>
<u>Asphalt / Dirt Midgets</u>	<u>10, 12</u>
<u>USAC Open Wheel</u>	<u>12, 14</u>
<u>Sprints</u>	<u>12, 14</u>
<u>Micro / Mini-Sprints</u>	<u>11, 15</u>
<u>Drag Cars</u>	<u>16</u>
<u>Vintage Class</u>	<u>10</u>
<u>Quarter Midgets</u>	<u>9</u>
<u>Road Race</u>	<u>17</u>
<u>Accessories</u>	<u>18, 19</u>
<u>Head Restraint Kits</u>	<u>20</u>



As KIRKEY RACING FABRICATION INC. enters its 25th year in business, we would like to thank all our loyal customers who have supported us over the years. With your support KIRKEY is now one of the largest seat manufacturers World Wide. The quality and comfort of our seats is proven on dirt and asphalt ovals, drag strips and road courses around the globe.

We have been at the leading edge of the race seat evolution over the years. Beginning with the low back standard aluminum seats to the full containment aluminum seats that we offer now. Over the years our philosophy has not altered, we continue to strive to offer both the professional and amateur driver a safe, lightweight, high quality seat at an affordable price.

How do we do this?

Unlike our competition we do not have “freebies”. Rest assured, you are not paying for your competitors seat when you line up beside them at the racetrack.

We build all our seats and covers entirely in-house at our modern manufacturing facility with quality workmanship. We use only the finest quality materials available. Our comfortable and stylish covers are die cut so each one fits the way it was intended. Each seat has been designed and engineered with CAD-CAM and built using CNC cutting, forming and welding technologies. By using the latest in technology we can keep our costs down and pass them on to you.

We are proud of the reputation we have earned. We know the pressures and deadlines that racers face and do our best to keep seats in stock and ready to ship throughout our dealer network.

Our business experience has always been that you can pay too much for something or pay too little. If you pay too little, it usually costs you more in the long run because a low-cost product rarely does what it's supposed to. It breaks, and you wind up buying the product you really wanted in the first place.

That's why we never scrimp on materials or workmanship when we build our seats

Our commitment is to build the strongest, the lightest, the safest aluminum race seat possible for our customers at an affordable price. After all these years, many of you and now your children, have become good friends. How could we, in good conscience, provide you with anything but the safest equipment possible?

Thanks again

Steve Kirkey

Tech Line: (613) 938-4885

Fax: (613) 938-6347

E-mail: kirkey@kirkeyracing.com

www.kirkeyracing.com

How do you pick the best seat

with our wide range of seats and prices? First you have to determine what the car's (and track's) intended speed will be. If you're just starting out in street or hobby stock, your speeds will be lower, you'll be on shorter tracks, G forces will be less and if you have an incident the chance of injury is less. You probably don't need our most advanced Total Containment Seat (but it would be a good investment if your budget can handle it). On the other hand, if you're running a Sprint or Speedway Car, you need all the strength and protection you can get. In general, the more advanced the class you run in, the more advanced a seat you will need. This is no place to try and save a few bucks.

The Custom Shop

Because we manufacture KIRKEY seats completely in house, we can easily custom tailor a seat for you if one of our standard sizes doesn't fit.

We can also custom design and build seats for any application. If it's got wheels or even if it doesn't, we can design a safe, comfortable race seat for it! There are KIRKEY seats in Monster Trucks, Tractor Pulls, Swamp Buggys, Unlimited Hydroplanes, you name it! If you have a special application, give us a call, we may have a seat in stock that will fit or we can design one to your specifications. Just remember that custom work takes a little longer.

Please measure your hips first — one of our standard sizes will probably fit you perfectly

We have built thousands of seats and have optimized the dimensions to fit almost everybody. If one of our standard sizes fit, you don't have to do the following measurements unless you want to check yourself against the seat dimensions. If none of our standard sizes fit we can custom tailor one to your measurements. Either way, your numbers must be accurate to chose the right seat.

NOTE: Extremely important — All measurements must be taken in absolutely straight lines.

Use a yardstick or stager gauge. If using a tape measure, DO NOT let it follow the curvature of the body.

A-Width of Chest- Gives width of seat at Rib Support. Have driver stand with arms raised slightly, measure side to side 1-1/2" below armpits (use two straight edges placed parallel under armpit).

B-Width of hips- Gives width of seat at hip area. Have driver sit on bench or table with legs hanging over side, measure width of hips through center line of body side to side. Do not measure across lap of driver, this will give a wider than required measurement. See the shop drawings for each seat.

C-Height of Armpit- Gives height of rib support. With driver still sitting on bench or table, measure from flat surface to armpit. Make sure drivers shoulders are completely level across back. Make sure driver is sitting with back completely straight.

D-Height of Shoulders- Gives height of shoulder harness opening. With driver sitting in same position as above, measure from flat surface to top of shoulder. If you are using the Hans Device please add 3/4" to the shoulder height.

E-Chest Depth- Gives length of rib supports. Have driver stand with back against wall, measure from wall to front of chest approximately 1-1/2" below armpit.

F-Shoulder Width- Gives width of shoulders for seats with built in shoulder supports. Have driver sit on flat surface and place hands as if they were on the steering wheel in the car. Put two straight edges on each side of the driver 1-1/2" below the flat part of the shoulder - see diagram below.

We will also need the drivers height and weight for custom seats.

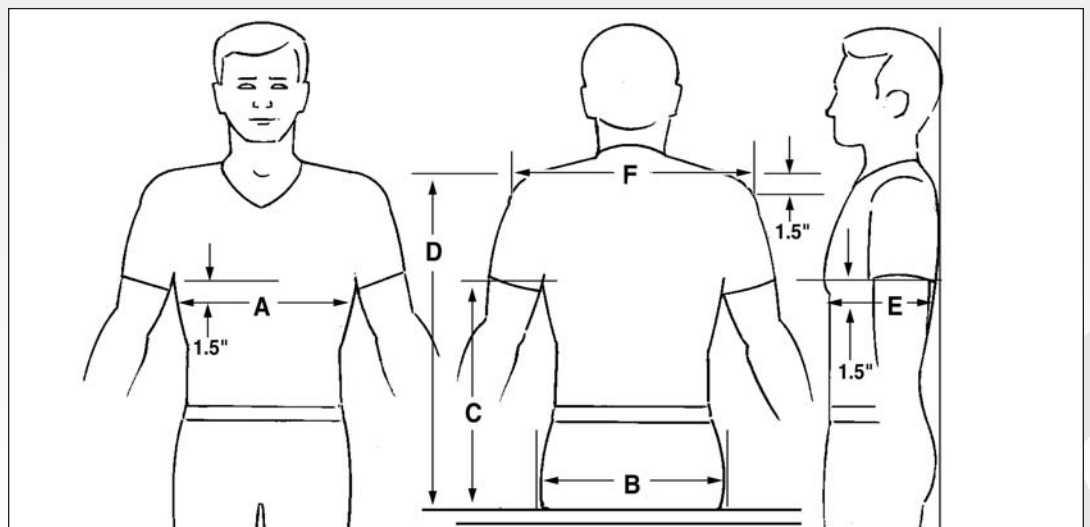

Cover Colors and Fabrics

NYLON			VINYL	CLOTH					AIRKNIT			
31 BLACK	32 RED	33 BLUE	01 BLACK	11 BLACK	12 RED	16 PURPLE	17 GREY	19 BLUE	41 BLACK	42 RED	47 GREY	49 BLUE

check out: www.kirkeyracing.com

KIRKEY

1

Full Containment Layback

Designed for Oval Track:

- Asphalt Modified
- Asphalt Late Models
- Road Racing
- Truck Series

Our **Full Containment Layback** seat offers the latest in racing seat technology. Designed for the serious racer who demands the very best in safety and comfort from a name they can trust. The complete seat is a modular three-piece unit. Each section can be easily replaced with a different sized component. Since each section is available in different sizes, it allows the individual to construct a custom fit seat without the custom seat price or delivery time.

- Unique three-piece design makes modification possible.
- Built to accommodate all head and neck restraint systems.
- Integrated head and shoulder restraint system.
- Shortened left-side head containment system also available for confined cockpits.
- Adjustable head containment system with energy absorbing impact foam.
- Contoured high-density foam bottom provides complete leg and inner thigh support.
- Padded rib supports for driver comfort and extra support.
- Reinforced shoulder restraint with energy absorbing impact foam.
- Aluminum extrusion around perimeter of seat.
- Elongated bottom for total leg support.
- Available in standard sizes 14" to 18" hip widths in 1" increments.
- Modular components assembled with grade five hardware.
- See website for mounting instructions.
- Optional leg extensions also available.
- Accommodates six point seat belts.



53 SERIES
Base Unit



53 SERIES
Shoulder Unit



53 SERIES
Standard Head Restraint Unit



53 SERIES
Regular Tubular Head Restraint



53 SERIES
Optional Leg Extensions

Full Containment Layback

Three components are needed for a complete seat; the seat base, shoulder restraint and head restraint.

Available Sizes

SHORT Seat Base:

Ribs are 1-1/2" lower

Hip Width	Part No.
14"	53100-S
15"	53300-S
16"	53500-S
17"	53700-S
18"	53900-S

REGULAR Seat Base:

Hip Width	Part No.
14"	53100
15"	53300
16"	53500
17"	53700
18"	53900

TALL Seat Base:

Ribs are 1-1/2" Higher

Hip Width	Part No.
14"	53100-T
15"	53300-T
16"	53500-T
17"	53700-T
18"	53900-T

SHOULDER RESTRAINT:

Shoulder Width	Part No.
18"	53SD18
19"	53SD19
20"	53SD20
21"	53SD21
22"	53SD22
23"	53SD23

HEAD RESTRAINT:

	Part No.
Regular	53H100
Short Left	53H200

TUBULAR HEAD RESTRAINT:

	Part No.
Regular Tube	53H300
Short Left Tube	53H400

Fabric & Colors

To order a specific cover, substitute the last two numerical digits of the seat number for one of the following:

Airknit

41 Black	42 Red
47 Grey	49 Blue

See pages 1 & 19 for colors.

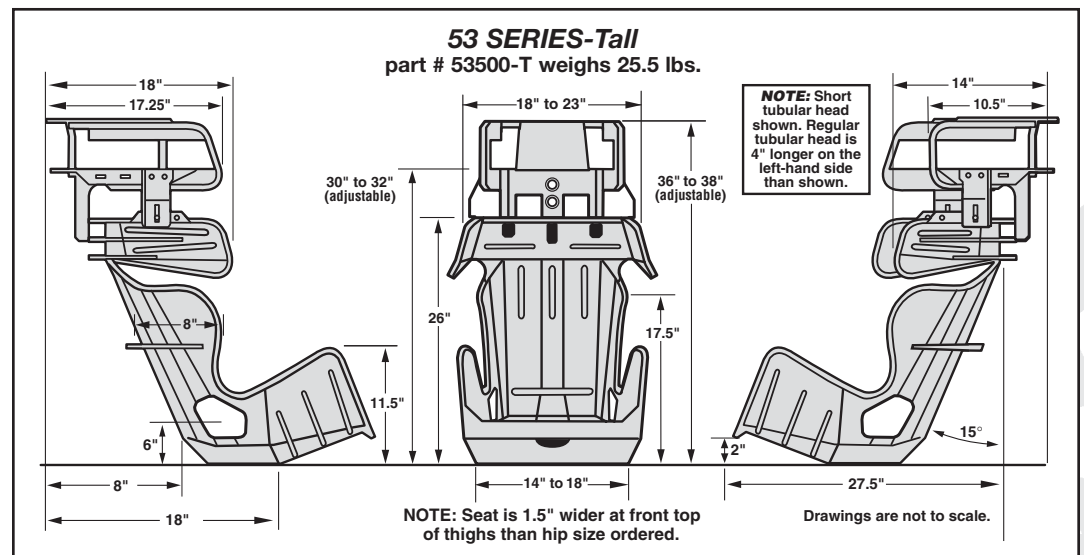
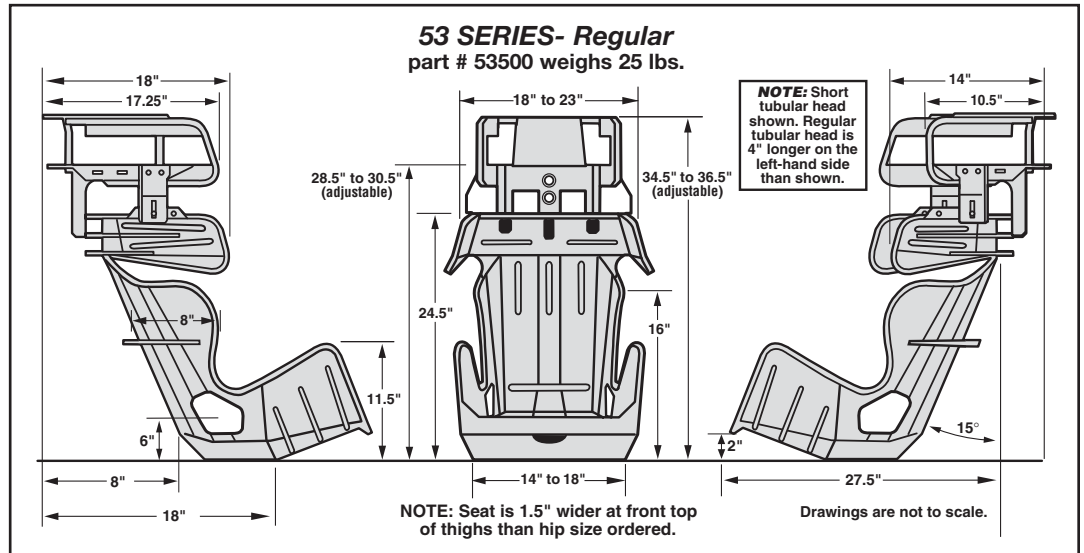
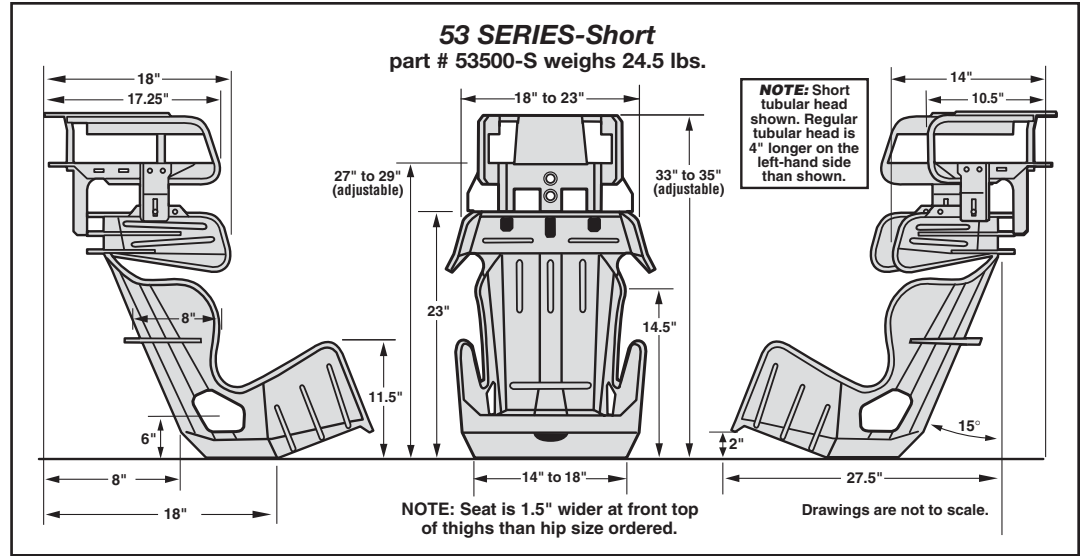

Layback Adjustable Containment Seat

Designed for Oval Track:

- Dirt Late Models
- Asphalt Late Models
- Street Stocks

Available Sizes

Hip Width	Part No.
14"	63100
15"	63300
16"	63500
17"	63700
18"	63900

Note: Measurement is driver's hips. See page 1 for details.

Fabric & Colors

To order a specific cover, substitute the last two numerical digits of the seat number for one of the following:

Airknit
41 Black
42 Red
47 Grey
49 Blue

See pages 1 & 19 for colors.

Leg Restraints



part # 02300

02300	Right Side
02400	Left Side

See pages 1 & 19 for colors.

Our new **Layback Adjustable Containment Seat** offers the latest in racing seat technology. The seat comes with adjustable head and shoulder restraints, which allows the driver to set-up the seat to their particular driving preference.

- Constructed from TIG welded .100" thick 5052 grade aluminum. MIG welded inside for added strength.
- Designed to accommodate all head and neck restraints.
- Integrated head and shoulder restraint system with high density energy absorbing impact foam.
- Head restraint height is adjustable.
- Shoulder restraint width, height and pitch are adjustable.
- Padded rib protectors for extra driver support.
- Rear of seat is reinforced with square tubing for added strength.
- Elongated bottom for increased leg support.
- Accommodates six point seat belts.

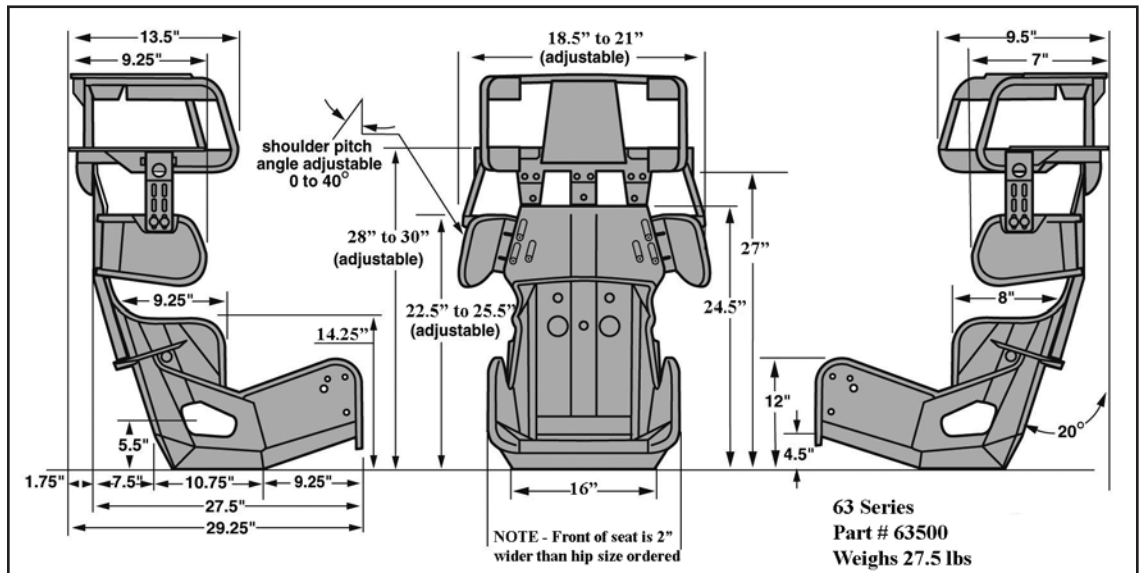

NOTE: above shop drawing is for the 16" version. Some dimensions will change with different seat sizes. See website for exact dimensions for the seat size you are interested in.

New Layback Containment Seat

Designed for Oval Track:

- Dirt Late Models
- I.M.C.A. Modifieds
- Short Track Asphalt Late Models
- Street Stocks

Our new *Layback Containment Seat* is designed for the short track racer who wants the added safety of a containment seat at a price they can afford. Designed using the same bottom that our Lightweight Layback seat has for years assures this seat will fit in your car with ease.

Available Sizes

Hip Width	Part No.
14"	68100
15"	68300
15.5	68400
16"	68500
17"	68700
18"	68900
Custom	68000

Note: Measurement is driver's hips. See page 1 for details.

Fabrics & Colors

To order a specific cover, substitute the last two numerical digits of the seat number for one of the following:

Vinyl	Cloth
01 Black	11 Black
	12 Red
	16 Purple
	17 Grey
	19 Blue

See pages 1 & 19 for colors.

- Constructed from TIG welded .100" thick 5052 grade aluminum. MIG welded inside for added strength.
- Unique design adds extra strength and keeps weight down.
- Designed to accommodate all head and neck restraints.
- Built in reinforced padded shoulder restraints.
- Reinforced vertically adjustable padded head restraint.
- Aluminum extrusion offset on perimeter of seat adds strength and keeps inside of seat smooth.
- Padded rib protectors for extra driver support.
- Contoured elongated bottom with extended leg supports and center leg separator.
- Accommodates six point seat belts.
- Easy to install cover.
- 18 degree layback.
- Designed to replace your existing Intermediate or Lightweight seat.
- Head restraint designed for easy entry and exit.



See website for shop drawings

Lightweight Layback

Designed for Oval Track:

- **IMCA Modified**
- **All Dirt Late Models**
- **Short Track Late Models**

Available Sizes

Hip Width	Part No.
14"	58100LW
14.5"	58200LW
15"	58300LW
15.5"	58400LW
16"	58500LW
16.5"	58600LW
17"	58700LW
Custom	58000LW

Note: Measurement is driver's hips. See page 1 for details.

Fabric & Colors

To order a specific cover, substitute the last two numerical digits of the seat number for one of the following:

Cloth
11 Black
12 Red
16 Purple
17 Grey
19 Blue

See pages 1 & 19 for colors.

Accessories



Lightweight Leg Supports

are available in matching upholstery and add extra side support to the legs under high Gs and accidents. See page 18.

Our Lightweight **Double Rib Support 20° Layback** is designed for the racer who wants to save weight but demands the ultimate in comfort and safety.

- Strategically placed flared openings save weight and add strength.
- .080" & .100" thick 5052 grade aluminum is TIG welded outside and MIG welded on inside for added strength.
- Contoured sides support hips and thighs along complete side of seat. Seat bottom shaped at rear to support tailbone and lower back. Center leg support holds inner thighs under heavy cornering forces.
- Aluminum extrusion around perimeter of seat adds strength and safety. Edge of seat is stepped and extrusion is offset to outside so inside of seat is completely smooth.
- Seat back is double crossbroke for added strength and safety.
- Front of seat is raised for thigh support.
- Seat bottom has been extended for extra leg and thigh support.
- Rib supports are reinforced with welded, lightweight flared band. Progressive rib bead added for extra strength.
- Double shoulder belt and sub belt openings standard.

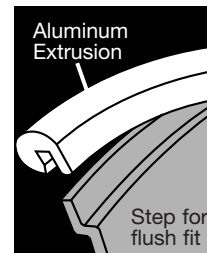

- Machined plate added to shoulder belt openings for increased strength.
- Full covers or lightweight four piece modular design available.
- Extra thick, high density foam on rib supports for added comfort and safety.

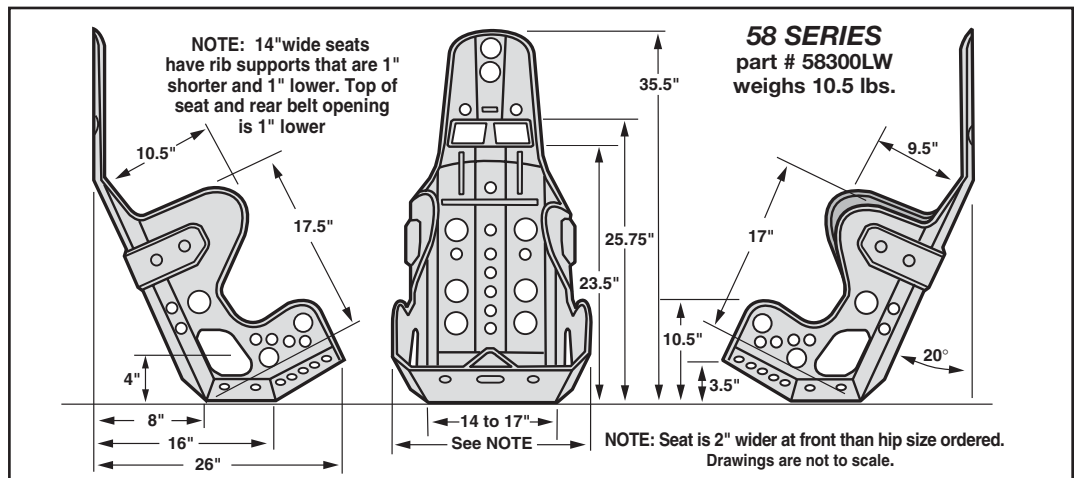

Intermediate 10° and 20° Layback

Designed for Oval Track:

- I.M.C.A. type Modifieds
- All Dirt Late Models
- Limited Asphalt Late Models
- SK Asphalt Modifieds
- Short Track Trucks (10°)
- D.I.R.T. Modifieds (10°)

Available Sizes 20°

Hip Width	Part No.
14"	36100
15"	36300
16"	36500
17"	36700
18"	36900
20"	36800
Custom	36000

Note: Measurement is drivers hips. See page 1 for details.

Available Sizes 10°

Hip Width	Part No.
14"	39100
15"	39300
16"	39500
17"	39700
18"	39900
Custom	39000

Note: Measurement is drivers hips. See page 1 for details.

Fabrics & Colors

To order a specific cover, substitute the last two numerical digits of the seat number for one of the following:

Vinyl	Cloth
01 Black	11 Black
	12 Red
	16 Purple
	17 Grey
	19 Blue

See pages 1 & 19 for colors.
See pages 18 & 19 for accessories.

Our *Intermediate 10° and 20° Layback* seats are designed especially for dirt and asphalt limited late models and IMCA type Modifieds. The Intermediate seat is a great value for the professional and amateur alike who demands the best in safety and comfort.

- TIG welded .125 thick 5052 grade aluminum. MIG welded inside for added strength.
- Offset aluminum extrusion around perimeter of seat for added rigidity.
- Progressive rib bead adds extra strength.
- Upholstery is double stitched around belt openings and all stress points.
- Multi-positional lap belt openings for easy mounting. Submarine belt opening is standard.
- Contoured high-density foam bottom provides complete leg and thigh support.
- High density foam on rib supports for added comfort.
- The 20" wide version has the bottom extended 2", rib extended and raised 1", and shoulder belt openings raised 1". It is available in black cloth or vinyl only.

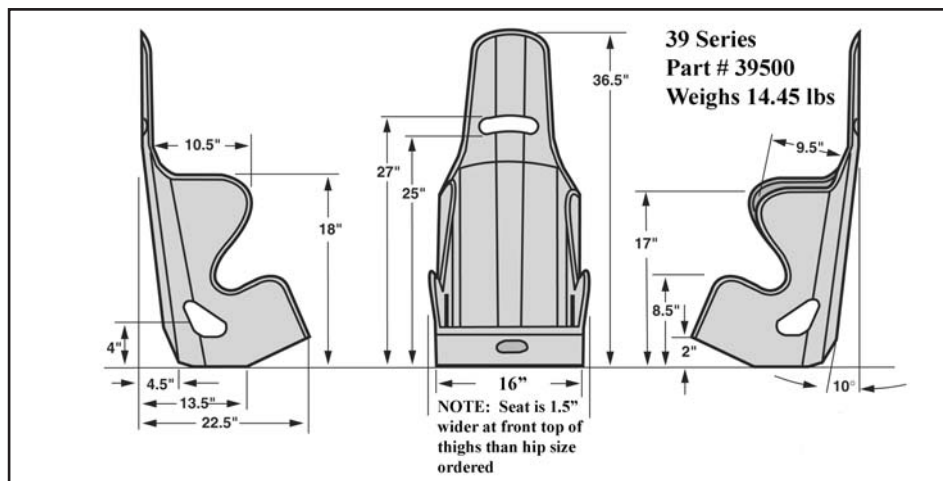
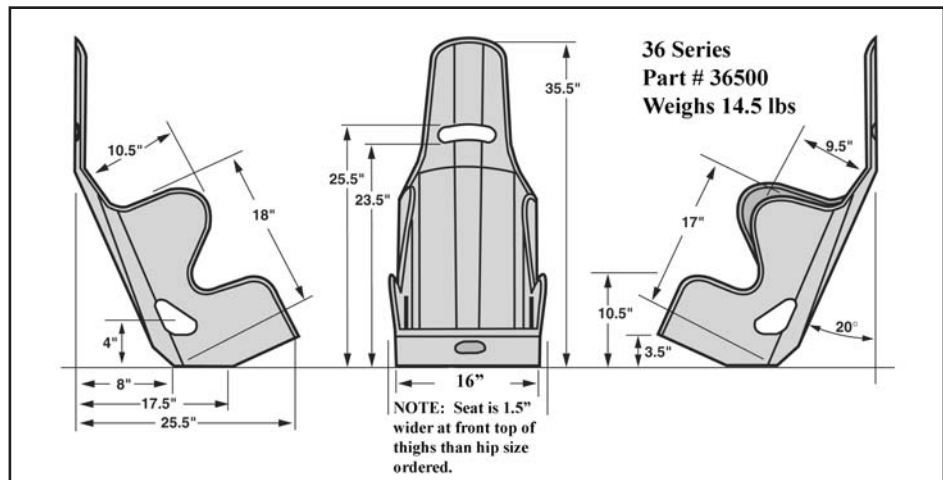

NOTE: above shop drawings are for the 16" version. Some dimensions will change with different seat sizes. See website for exact dimensions for the seat size you are interested in.

Economy Layback

**Designed for
Oval Track:**

- **Street Stocks**
- **All Entry Level Classes**

Double Rib Support 20° Layback Available Sizes

Hip Width	Part No.
14.5"	09200
15.5"	09400
17.5"	09800

Double Rib Support 10° Layback Available Sizes

Hip Width	Part No.
14.5"	19200
15.5"	19400
17.5"	19800

Note: Measurement is driver's hips. See page 1 for details.

Fabric & Colors

To order a specific cover, substitute the last two numerical digits of the seat number for one of the following:

Nylon

31 Black

32 Red

33 Blue

See pages 1 & 19 for colors.

Double Rib 10°/20° Layback

Our most inexpensive seats have the same KIRKEY quality as our most expensive! Our layback designs offer extra headroom for all chassis and entry level racing classes. You can be sure that regardless of price and features, we never scrimp on safety or materials.

- Designed for low horse power cars on small tracks. ■ Seat sides lowered for lap belts.
- MIG welded .125" thick 5052 grade aluminum. ■ Progressive rib bead adds extra strength.
- Seat bottom is contoured to support lower back and hips.
- Submarine belt opening is standard. ■ Rubber moulding around perimeter of seat.
- Headrest reinforced with offset aluminum extrusion. ■ Water resistant nylon cover.
- Extra thick, high-density foam padding on bottom to support thighs.



**09 Series
Double Rib 20° Layback**

- Extra padding added in rib area for safety and comfort.
- Upholstery is double stitched around belt openings and all stress areas.
- Double rib support available in 10° and 20° layback version.
- 14.5" seat uses the same cover as the 15.5" seat.



**19 Series
Double Rib
10° Layback**

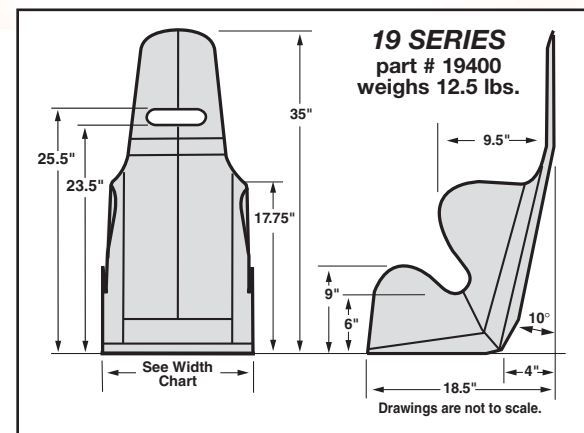
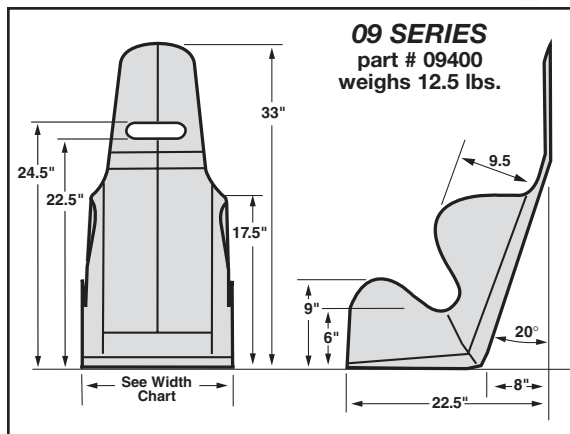

Economy "Big Boy" Seat

Designed for:

- Entry Level Classes
- Street Stocks

Available Sizes

Hip Width	Part No.
21"	20900

Note: Measurement is driver's hips. See page 1 for details.

Cover

To order a specific cover, substitute the last two numerical digits of the seat number for one of the following:

Vinyl

20901 Black vinyl only

Designed for the larger racer, this seat has all of the same features as our economy line of seats plus these added features:

- Progressive rib bead adds extra strength.
- Extended bottom and rib supports for added support.
- Raised shoulder belt opening.
- Extra thick padding on rib support.
- Headrest is reinforced with an offset aluminum extrusion.
- Single rib design for easier entry and exit.

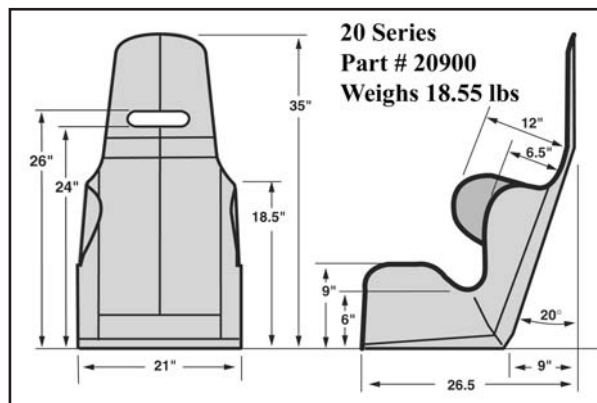

Designed for:

- Quarter Midgets

Available Sizes

Hip Width	Part No.
10"	24900
11"	24100
12"	24200
13"	24300
14"	24400

Note: Measurement is driver's hips. See page 1 for details

Cover

To order a specific cover, substitute the last two numerical digits of the seat number for one of the following:

Nylon

31 Black only

Child Seat

- TIG welded .100" thick 5052 grade aluminum. MIG welded on inside for added strength.
- Headrest is reinforced with an offset aluminum extrusion.
- Water resistant nylon upholstery is double stitched around belt openings and all stress points.
- Multi-level shoulder harness cutouts and submarine belt openings are standard.
- 10", 11" and 12" seats have rib supports and headrest lowered one inch for smaller children.

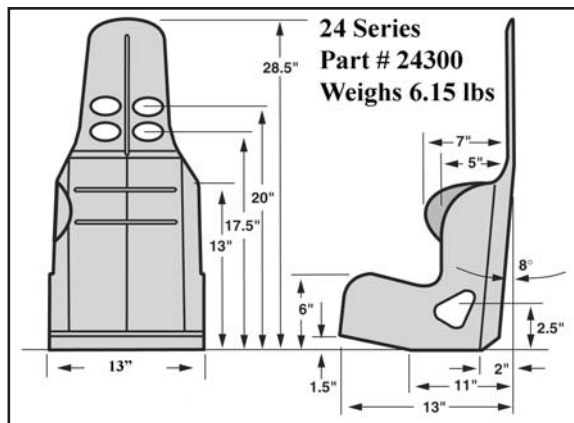

Accessories



part # 00100C

Child Head Support

Available in the same colors as the seat

00100C	Right Side
00200C	Left Side

4.5" Nose Pad

00031 Black



part # 00031

4.5" Nose Pad

Attaches to steering wheel with velcro.

Intermediate Youth Layback

Designed for:

- Modified Lights
- Dwarf Cars

Available Sizes

Hip Width	Part No.
14"	36100-C

Note: Measurement is driver's hips. See page 1 for details.

Fabric & Colors

To order a specific cover, substitute the last two numerical digits of the seat number for one of the following:

Cloth

- 11 Black
- 12 Red
- 16 Purple
- 17 Grey
- 19 Blue

Our **Intermediate Youth Layback** is basically a scaled down version of our 36 series seat. It has all the same features and benefits of the 36 series and is designed for smaller cars.

- .125" thick 5052 grade aluminum, TIG welded outside and MIG welded on inside.
- Offset aluminum extrusion around perimeter of seat adds strength and safety.



- Multi-position lap belt openings for easy mounting. Submarine belt opening is standard.
- Contoured high-density foam bottom.
- Extra thick padding on rib support.

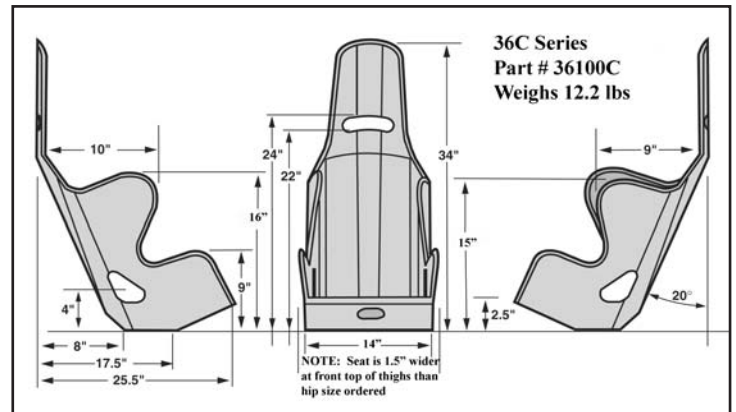

Vintage Class Bucket Seat

Designed for:

- All Vintage Classes

Available Sizes

Hip Width	Part No.
15"	41300V
16"	41500V
17"	41700V
18"	41900V

Note: Measurement is driver's hips. See page 1 for details.

Cover

To order a specific cover, substitute the last two numerical digits of the seat number for one of the following:

Vinyl

- 01 Black

Our **Vintage Class Bucket Seat** was designed especially for vintage class racing. Its low back construction and upholstery design gives it the vintage look but is still constructed with today's technology.

- TIG welded .100" thick 5052 grade aluminum. MIG welded inside for added strength.
- Offset aluminum extrusion around perimeter of seat for added strength and safety.
- Contoured and extra thick, high-density foam bottom provides complete leg and inner thigh support.
- Unique vertical stitching design on cover for that true vintage look.

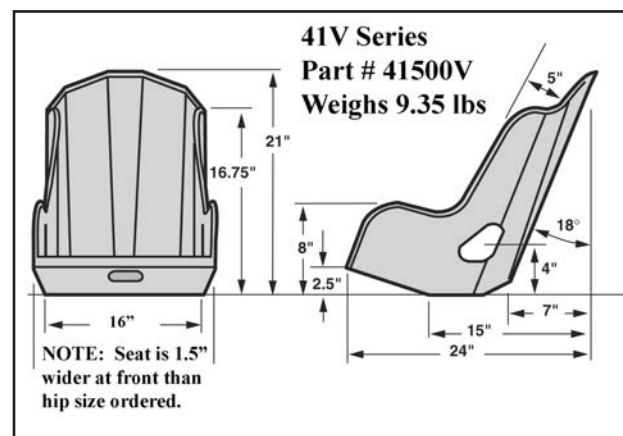

Open Wheel Full Containment Seat

Micro/Midget

Designed for
Oval Track:

- Mini Sprints
- Micro Sprints
- Midgets

Available Sizes

Hip Width	Part No.
13"	67013
14"	67100
14.5"	67200
15"	67300
15.5"	67400
16"	67500

LEG PROTECTOR:

	Part No.
*Leg Protector	99600
*Attaches to seat	

*Leg Protector	99502
*Attaches to steering column	

part # 99502



Fabrics & Colors

To order a specific cover, substitute the last two numerical digits of the seat number for one of the following:

Vinyl	Tweed Cloth
01 Black	11 Black
	12 Red
	16 Purple
	17 Grey
	19 Blue

See pages 1 & 19 for colors.

Our **Open Wheel Containment Seat** offers the latest in racing seat technology. Designed for the serious racer who demands the very best in safety and comfort from a name they can trust. Comes with adjustable head and shoulder restraints. Since head and shoulder restraints are adjustable, it allows the individual to construct a custom fit seat without the custom price and delayed delivery time.

- Unique design makes adjustment possible.
- Designed to accommodate all head and neck restraint systems.
- Reinforced head and shoulder restraint system with energy absorbing impact foam.
- Strategically placed flared openings to lighten and strengthen seat.
- Padded rib supports for extra driver comfort.
- Rib supports strengthened with welded formed plate.
- Offset aluminum extrusion around perimeter of seat for added rigidity.
- Easy to install full back cover.
- Comes with universal mounting brackets.
- Accommodates six point belts.

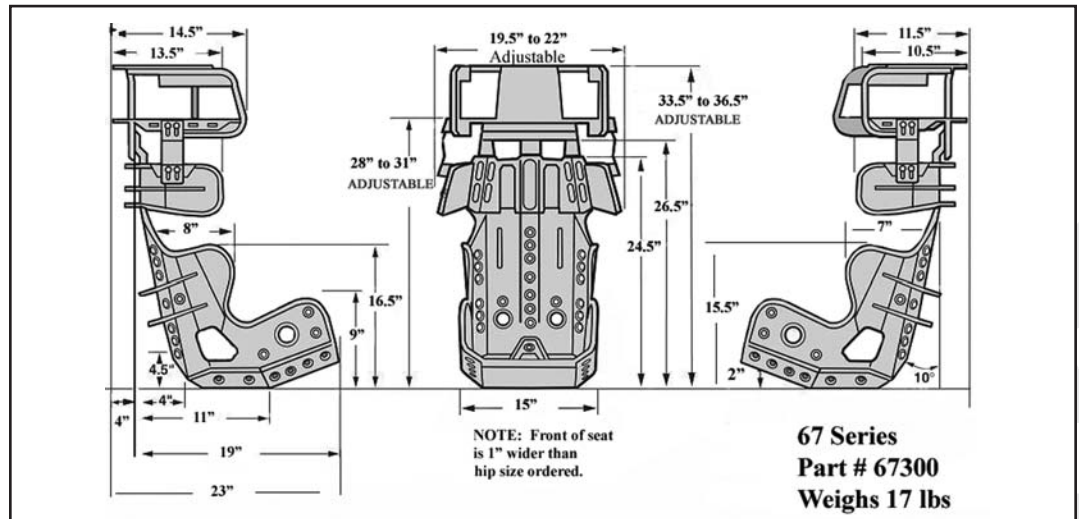

NOTE: above shop drawings are for the 15" version. Some dimensions will change with different seat sizes. See website for exact dimensions for the seat size you are interested in.

Open Wheel Full Containment Seat

Designed for Oval Track:

■ Sprints

■ D.I.R.T Modified

■ USAC Open Wheel

Our *Open Wheel Full Containment Seat* offers the latest in racing seat technology. Designed for the serious racer who demands the very best in safety and comfort from a name they can trust. Comes with adjustable head and shoulder restraints. Since head and shoulder restraints are adjustable, it allows the individual to construct a custom fit seat without the custom price and delayed delivery time.

Tubular head restraint height is easily adjusted using the pre-drilled holes.

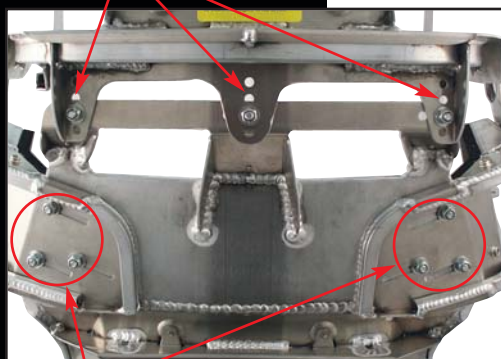

Shoulder restraint height and width are easily adjusted using the pre-milled slots in the seat.

- Unique design makes adjustments possible.
- Designed to accommodate all head and neck restraints systems.
- Reinforced head and shoulder restraint system with energy absorbing impact foam.
- Head restraint is shorter on the left-hand side to ease vehicle entry and exit.
- Elongated bottom for added support.
- Strategically placed flared openings to lighten and strengthen seat.
- Padded rib supports for extra driver comfort.
- Rib supports strengthened with welded formed plate.
- Offset aluminum extrusion around perimeter of seat for added rigidity.
- Easy to install full back seat cover.
- Comes with universal mounting brackets.
- Accommodates six point seat belts.



Open Wheel Full Containment Seat

Available Sizes

SHORT Seat Base:

Hip Width	Part No.
14"	66100S
14.5"	66200S
15"	66300S
15.5"	66400S
16"	66500S
17"	66700S

REGULAR Seat Base:

Hip Width	Part No.
14"	66100
14.5"	66200
15"	66300
15.5"	66400
16"	66500
17"	66700

TALL Seat Base:

Hip Width	Part No.
14"	66100T
14.5"	66200T
15"	66300T
15.5"	66400T
16"	66500T
17"	66700T

Accessories

	Part No.
Leg Extension	11700
Leg Protector	99600

Fabrics & Colors

To order a specific cover, substitute the last two numerical digits of the seat number for one of the following:

Vinyl	Cloth
01 Black	11 Black
	12 Red
	16 Purple
	17 Grey
	19 Blue

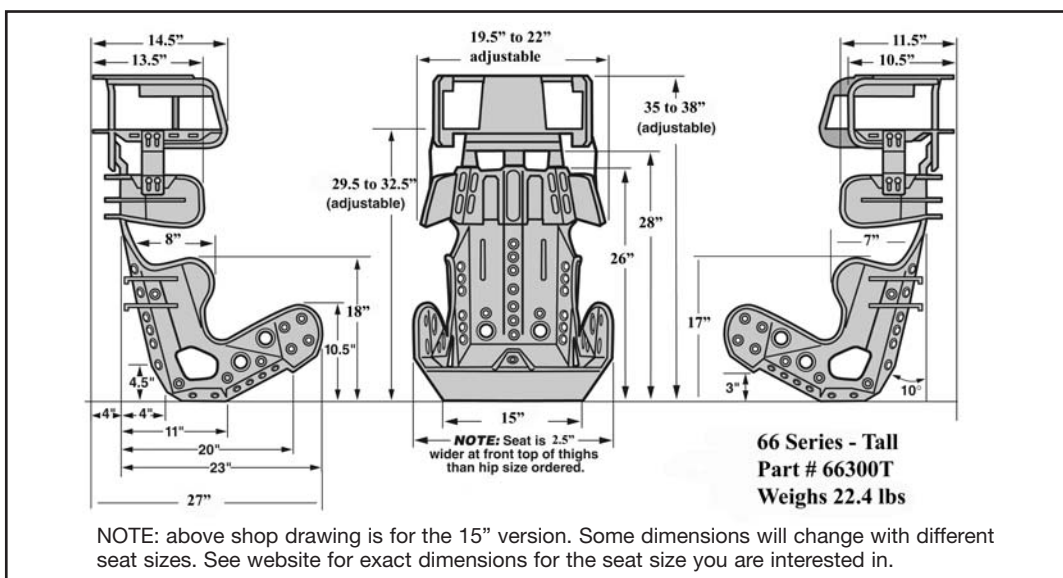
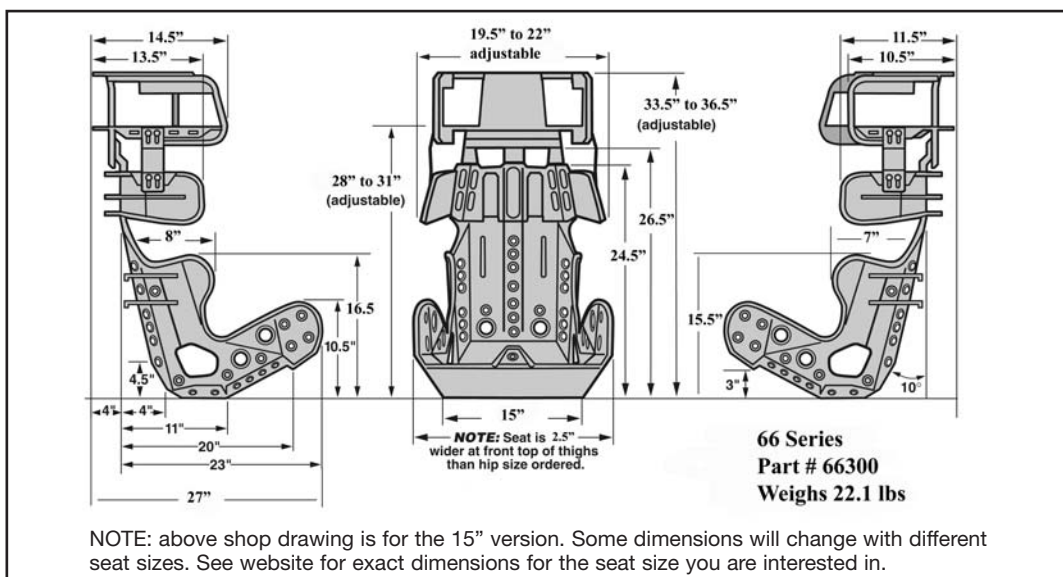
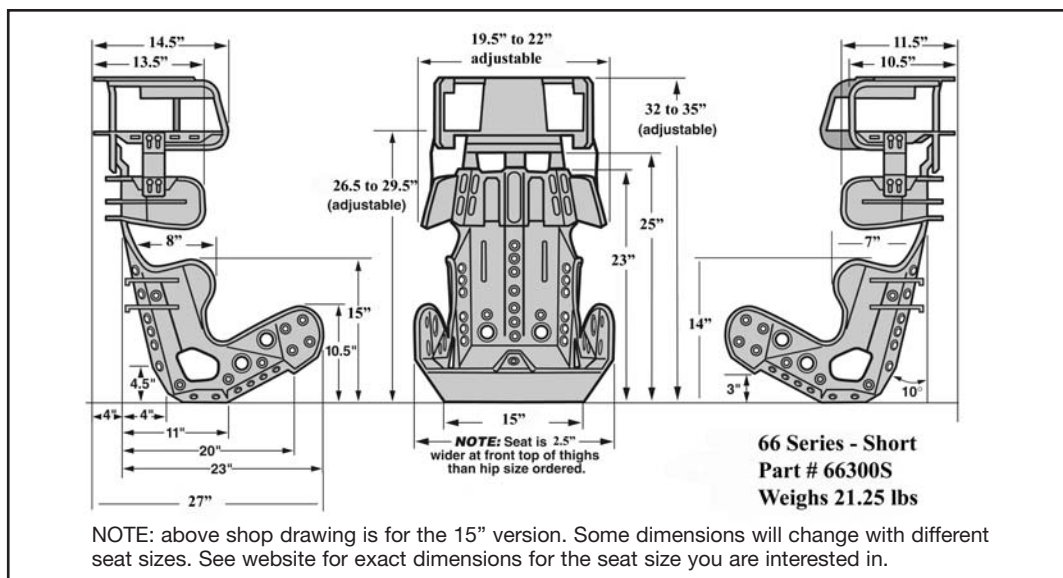

Sprint Deluxe Upright

Designed for Oval Track:

- Sprints
- Mini Sprints
- Midgets
- USAC Open Wheel
- D.I.R.T. Modifieds

Available Sizes Lightweight Version

Hip Width	Part No.
13"	56013LW
13.5"	56135LW
14"	56100LW
14.5"	56200LW
15"	56300LW
15.5"	56400LW
16"	56500LW
16.5"	56600LW
17"	56700LW
Custom	56000LW

Note: Measurement is driver's hips. See page 1 for details.

Available Sizes Solid Version

Hip Width	Part No.
14"	56100
14.5"	56200
15"	56300
16"	56500
17"	56700
18"	56900
Custom	56000

Note: Measurement is driver's hips. See page 1 for details.

Fabric & Colors

To order a specific cover, substitute the last two numerical digits of the seat number for one of the following:

Cloth

- 11 Black
- 12 Red
- 16 Purple
- 17 Grey
- 19 Blue

See pages 1 & 19 for colors.
See pages 18 & 19 for accessories.

- Available in a lightweight and solid version.
- Solid version available in black cloth only.
- Lightweight version has strategically placed flared openings to lighten and strengthen seat.
- TIG welded .080" & .100" 5052 grade aluminum. MIG welded inside for added strength.
- Offset aluminum extrusion around perimeter of seat for added rigidity.
- Progressive rib bead adds extra strength.
- Upholstery is double stitched around belt openings and all stress points.
- Multi-positional lap belt openings for easy mounting. Submarine belt opening is standard.
- Machined plate added to reinforce shoulder belt openings.
- Seat back is double cross broke for added strength and comfort.
- High-density foam on rib supports for added comfort.



Lightweight Version



Solid Version



part # 00300LW

Lightweight leg support - See p.18



part # 99502

Leg protector - See p.18

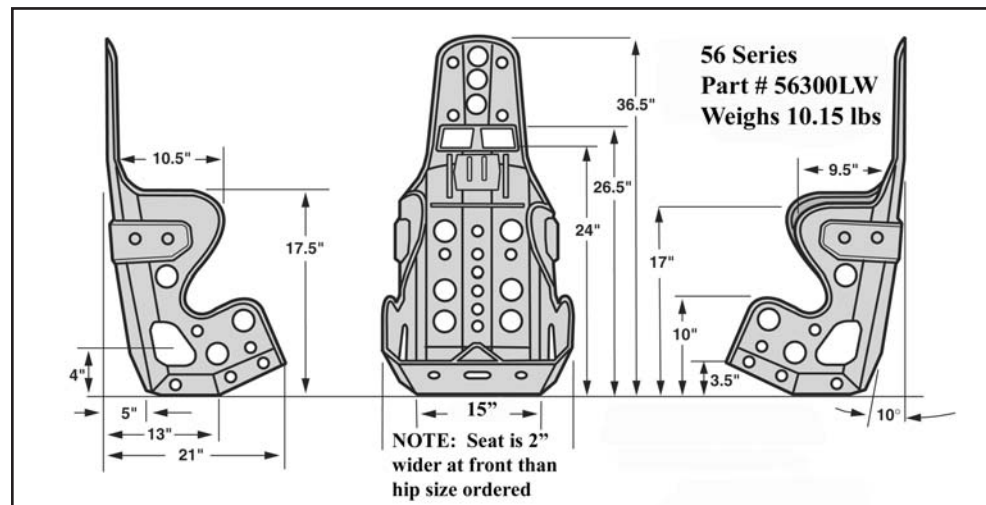

NOTE: above shop drawings are for the 15" version. Some dimensions will change with different seat sizes. See website for exact dimensions for the seat size you are interested in.

Lightweight Micro/Mini Sprint

Designed for Oval Track:

- **Micro Sprints**
- **Mini Sprints**

Available Sizes

OFFSET SIDE SIZES:

Hip Width	Part No.
14"	51100LW
15"	51300LW
16"	51500LW

Note: Measurement is driver's hips. See page 1 for details.

STRAIGHT SIDE SIZES:

Hip Width	Part No.
13"	52013LW
14" - Short	52100LW-S
14"	52100LW
14.5"	52200LW
15"	52300LW
16"	52500LW

Note: Measurement is driver's hips. See page 1 for details.

Fabric & Colors

To order a specific cover, substitute the last two numerical digits of the seat number for one of the following:

Cloth

- 11 Black
- 12 Red
- 16 Purple
- 17 Grey
- 19 Blue

See pages 1 & 19 for colors.

Our **Lightweight Micro/Mini Sprint Seat** is designed to be used in the smaller open wheel race cars, it is basically a scaled down version of our **Lightweight Sprint Car Seat**.

- Constructed from TIG welded .080" & .100" thick 5052 grade aluminum. MIG welded inside for extra strength.
- Strategically placed flared openings save weight and add strength.
- Aluminum extrusion around perimeter of seat adds strength.
- Seat back is double crossbroke for added strength and safety.
- Rib supports are reinforced with a welded lightweight flared band.
- Machined plate added to shoulder belt openings for increased strength.
- Lightweight four-piece modular cover available.
- 51 series has offset left-hand side for drive chain clearance. Right side offset out for leg and thigh clearance.

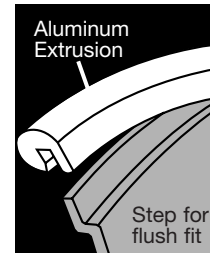

51 Series shown

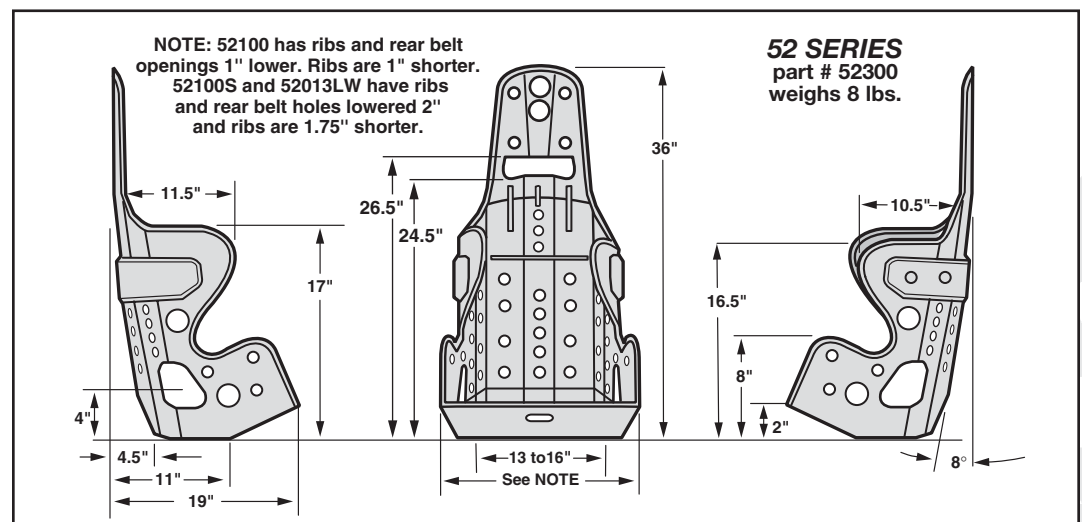
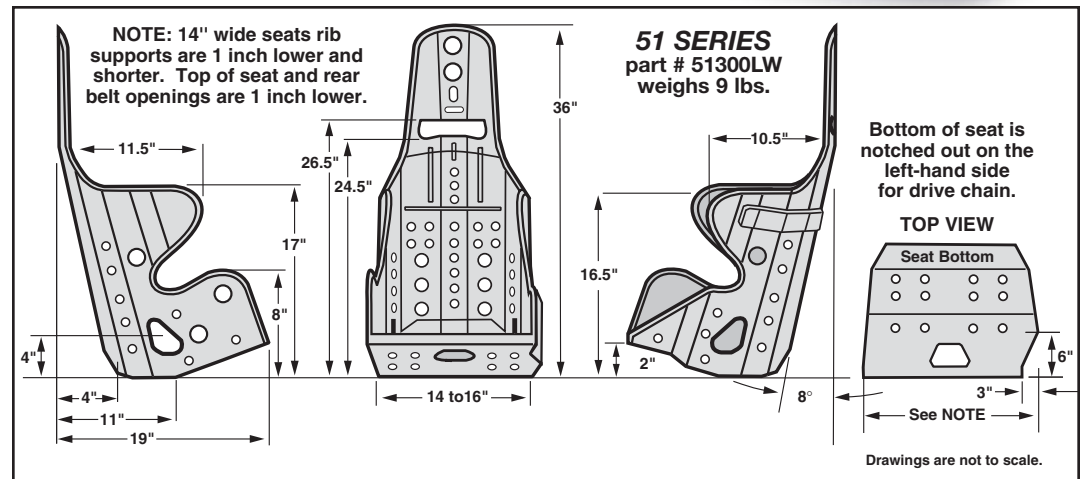

Economy Drag Seat

Designed for:

■ **Entry Level Drag Racing**

Available Sizes

Hip Width	Part No.
15.5"	16400
17.5"	16800

Note: Measurement is driver's hips. See page 1 for details.

Fabric & Colors

The last two digits of the seat part number denotes the color.

Nylon

31 Black
32 Red
33 Blue

Our most inexpensive drag seat has the same KIRKEY quality as our most expensive! You can be sure that regardless of price and features, we never scrimp on safety or materials.

- Constructed from MIG welded .125" thick 5052 grade aluminum.
- Seat sides are lowered for lap belts. Shoulder and Submarine belts are standard.
- Seat bottom is contoured to support lower back and hips.
- Rubber molding around perimeter of seat.
- Water resistant nylon cover.

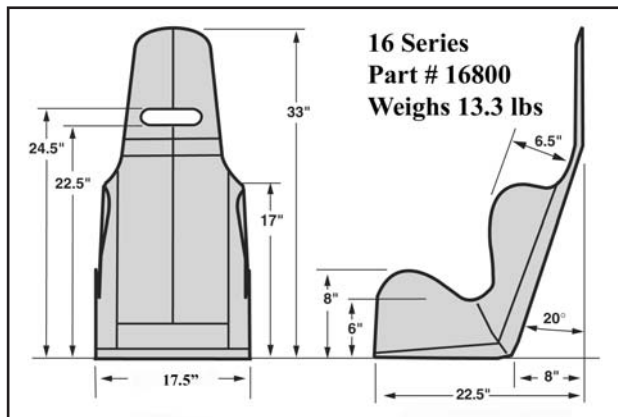

Pro-Street Drag Seat

Designed for:

■ **All Door Slammers**

Available Sizes

Hip Width	Part No.
15"	41300
16"	41500
17"	41700
18"	41900
20"	41800
Custom	41000

Note: Measurement is driver's hips. See page 1 for details.

Fabrics & Colors

To order a specific cover, substitute the last two numerical digits of the seat number for one of the following:

Vinyl	Tweed Cloth
01 Black	11 Black
	12 Red
	16 Purple
	17 Grey
	19 Blue

See pages 1 & 19 for colors.

A professional racing seat is just as important in a drag car as it is in an oval track car or road racer. The increased feel for the car through the seat will help you with chassis set-up and give you more consistent times. You will be able to concentrate on the lights better if you are comfortable and relaxed.

- Constructed from MIG welded .100" thick 5052 grade aluminum. MIG welded on the inside for added strength.
- Offset aluminum extrusion around perimeter of seat for added strength and safety.
- Contoured high-density foam bottom provides complete leg and thigh support.
- High-density foam on rib supports for added comfort.
- 41800 has bottom extended 2", rib extended and raised 1", and shoulder belt openings raised 1".

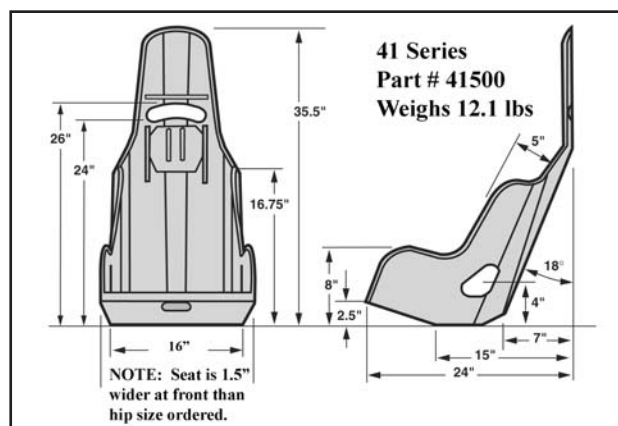

Intermediate Road Race

Designed for all Road Race Cars:

- Production Based GT, Sports Cars
- Trans Am
- Stock Cars

Available Sizes

Hip Width	Part No.
15"	47300
16"	47500
17"	47700
18"	47900

Note: Measurement is for driver's hips. See page 1 for details.



Our **Intermediate Road Race Layback** seat is designed especially for entry level road course cars. It has the same quality construction as our Deluxe seat at an affordable price. This seat is very comfortable making it ideal for endurance events.

- Constructed from TIG welded .125" thick 5052 grade aluminum. MIG welded inside for added strength.
- A true road race design with built in shoulder support.
- Aluminum extrusion around perimeter for extra strength and safety.
- Entire seat is padded with high density foam for extra comfort and support.
- Contoured head rest is designed to cup helmet.
- Extra support at rib height provides support for high G force cornering but is designed to not interfere with shifting.
- Available in four popular widths.
- Choose from four colors of the same high quality upholstery fabric as used on our circle track seats.
- Also available in airknit fabric for an additional charge. Call for details.



Fabric & Colors

To order a specific cover, substitute the last two numerical digits of the seat number for one of the following:

Tweed Cloth

11	Black
12	Red
17	Grey
19	Blue

See pages 1 & 19 for colors.

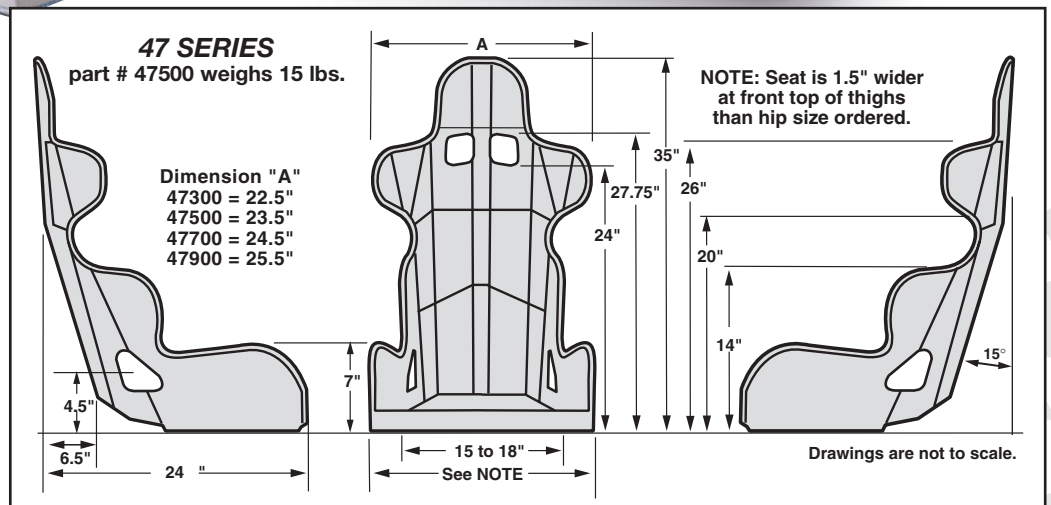

Seat Side Supports

You can customize any standard KIRKEY seat by bolting on these Head, Shoulder and Leg Supports. They can be easily installed on any KIRKEY seat and make it even safer and more comfortable. They give increased side support to the thighs, shoulders and head under heavy cornering and especially in case of a side impact. These side supports are made out of the same grade of aluminum as the seat and are available in the same fabrics and colors.

Head Support

	Right	Left
Support	00100	00200
Vinyl Cover	00101	00201
Cloth Cover	00111	00211
Nylon cover	00131	00231

Shoulder Support

	Right	Left
Support	00500	00600
Vinyl Cover	00501	00601
Cloth Cover	00511	00611

Leg Support

	Right	Left
Support	00300	00400
Vinyl Cover	00301	00401
Cloth Cover	00311	00411

Seat side supports can be ordered in any of the standard materials and colors listed in the chart with each seat. Substitute the last two numbers in the support part number with the appropriate color number.



Special Lightweight Seat Leg Supports

You can customize the new KIRKEY Lightweight seats with these matching leg supports.

	Right	Left
LW Leg Supports	00300LW	00400LW

For use on 56LW and 58LW Series seats only.



Deluxe Leg Restraints

Padded leg restraints can be added to any KIRKEY seat. They are 20" long, much longer than the leg supports above.

	Right	Left
Leg Restraints	01300	01400



Sprint Car Center Steering Pads

- One inch high-density foam pad sewn in center
- Wraps around the spokes of a three spoke steering wheel

Sprint Car Steering Pad	Black	00021
	Red	00022
	Blue	00023



Lumbar Support

- High-density padding gives added support to lower back area

Lumbar Support	99020
----------------	-------

Center Steering Pads

- 6" Diameter, 2" thick, high-density foam
- Velcro loops attach to steering wheel
- 3 spoke available in 3 colors
- 4 spoke available in black only

Three Spoke	Four Spoke
Black 00001	Black 00011
Red 00002	
Blue 00003	



Sprint and Midget Leg Protector

- Lightweight aluminum formed to surround center steering unit
- Bead rolled for extra strength

Center Leg Protector	99500	sprint
Center Leg Protector	99502	midget
Center Leg Protector	99600	(Bolts to seat)



Seat Mounting Bracket Kit

This kit will give you the safest mounting possible and save you hours of work, too. By simply rotating the tubes, you can mount this kit directly to the main hoop and door bars.

Seat Mounting Kit 99200
(welding required)



Upper Bracket



Lower Brackets

Seat Brackets

- Mounts seat to existing roll bar tubes

Upper bracket(use one) 99202
Lower brackets(pair) 99204

99204 can be used with 36, 41, 43, 47 series seats.



Roll Bar Padding

- Available in 3 foot lengths
- Fire retardant high-density padding
- Offset hole provides more protection towards driver

Black 99001 Orange 99005
Red 99002 Purple 99006
Blue 99003 Grey 99007
Yellow 99004

Not recommended for use overhead, use high-density padding.



14" long 3" diam. 18" long, 5" diam.

Coil Over Covers

- Vinyl covers keep out mud and rocks
- Two sizes to fit small and standard bodied coil overs (see chart)
- Velcro closing for easy spring adjustment
- Available in three colors

Large Coil Over Covers

Black 00041
Red 00042
Blue 00043

Small Coil Over Covers

Black 00051
Red 00052
Blue 00053

High-Density Roll Bar Padding

- The ultimate roll bar padding!
- Half circle design protects you, saves weight and costs less. Available in two diameters.
- Mounts easily with self-adhesive backing (except 99031, 99032 and 99033).

1-1/2" to 1-7/8" tubing			7/8" to 1-3/8" tubing		
SFI 45.1	Black	99011	SFI 45.1	Black	99021
SFI 45.1	Red	99012	SFI 45.1	Red	99022
SFI 45.1	Blue	99013	SFI 45.1	Blue	99023
	Back	99031			
	Red	99032			
	Blue	99033			



Tear Offs

- NEW fumble free super grip tabs eliminate slippage when tearing off
- .002 thin visually superior clear shield

Standard Straight 11.5"	1001
Tear Off Posts	1002
Bell Helmet 12.25"	1003
Rx 4-6-8 Bandit	1009
SX 4-6-8	1010
Shark/Super Sharp	1011
Biffe	1015
Impact Charger	1021
Impact Champ	1022



Quick Change Gear Pan

- All aluminum construction
 - Easy to pour hot oil with built in corner spout
 - Comfortable ergonomic handle
- 99100

Available Colors and Fabrics

NYLON	CLOTH
31 BLACK	11 BLACK
32 RED	12 RED
33 BLUE	16 PURPLE
VINYL	17 GREY
01 BLACK	19 BLUE

AIRKNIT

41 BLACK	42 RED	47 GREY	49 BLUE
----------	--------	---------	---------

Head & Shoulder Restraint Kit

Designed for:

■ **All Kirkey Adult Seats**

Our **Head & Shoulder Restraint Kit** allows you to retro fit your existing Kirkey seat to take advantage of the added safety that a head and shoulder restraint system offers. These kits must be used complete in order to be effective; the head restraint cannot be used separately. The kits are made from .100" 5052 grade aluminum and padded with energy absorbing impact foam. All mounting hardware is included with the kit.

Complete Unit Part Numbers

Kits include the head and shoulder restraints with covers, brackets and hardware.

Tubular Head Restraint

Fabrics & Colors Part No.

Black vinyl	98801
Black cloth	98811
Red cloth	98812
Purple cloth	98816
Gray cloth	98817
Blue cloth	98819

Standard Head Restraint

Fabrics & Colors Part No.

Black vinyl	98701
Black cloth	98711
Red cloth	98712
Purple cloth	98716
Gray cloth	98717
Blue cloth	98719

Short Head Restraint

Fabrics & Colors Part No.

Black vinyl	98701S
Black cloth	98711S
Red cloth	98712S
Purple cloth	98716S
Gray cloth	98717S
Blue cloth	98719S

Tubular Head Restraint Kit

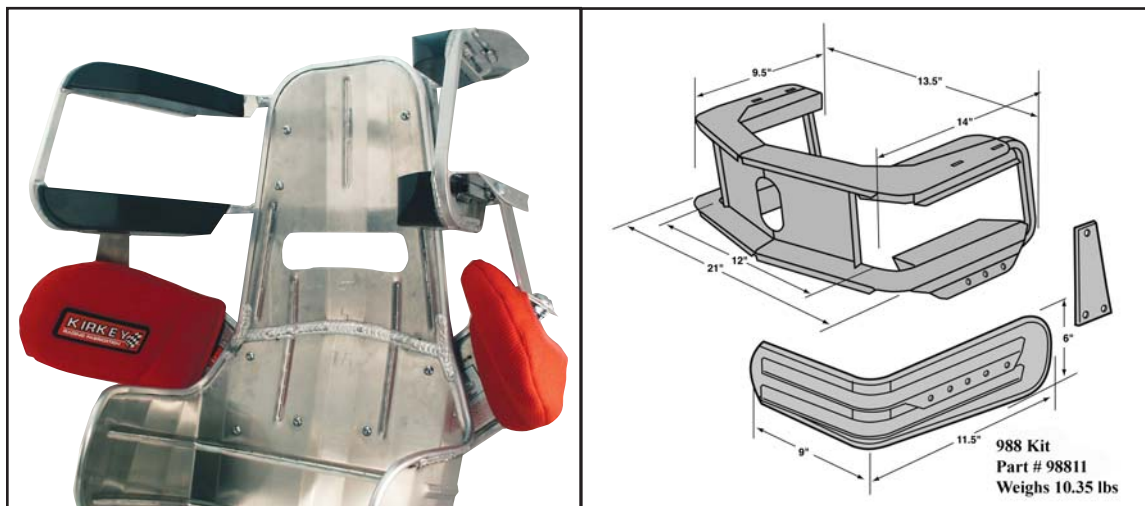

Standard Head Restraint Kit

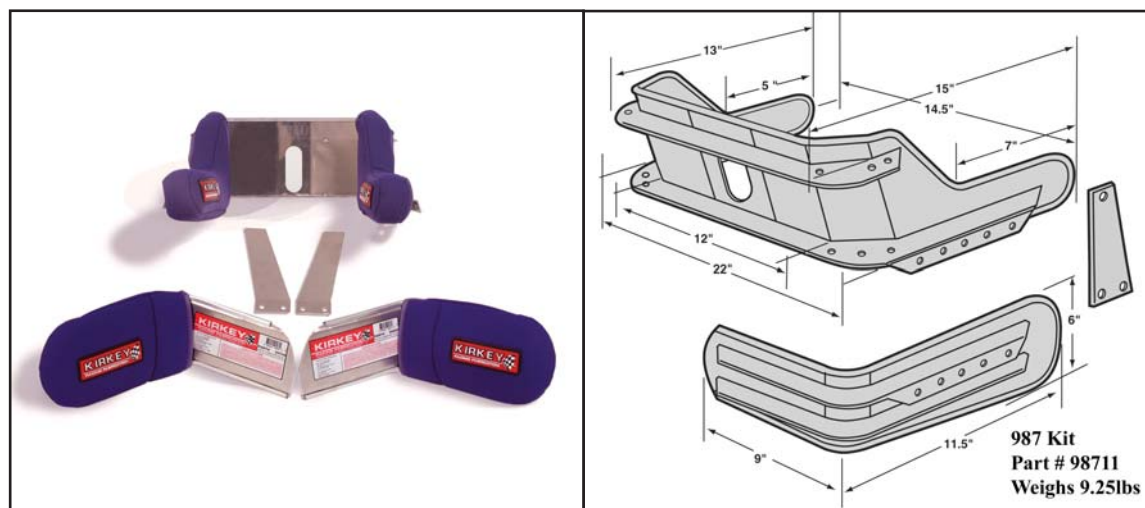

NOTE: These kits are not designed for economy seats, or child seats.

How do I mount a KIRKEY RACING seat?

How you install is really up to you; however we do recommend the following. One, that the seat be mounted to the roll cage or structural member of the frame. Two, that you bolt the seat in six places, four on the seat bottom and two just below the shoulder belt holes. We recommend against the use of stock sliders and adjusters as these can let go in a high impact crash. For entry level classes we do offer a mounting kit but a roll cage is required to use it. Be sure to check with your sanctioning body and /or track for their rules and regulations on seat installation. See our website for complete installation instructions.

Can I still get a seat cover for my discontinued seat?

The best way to ensure that you get the correct replacement cover for your discontinued seat is to send us your old cover. From this we can make a new one. Sometimes if you have the part number for the old seat we can make a replacement, but the fit is not guaranteed. The cost for a discontinued cover is higher than a regular cover.

Will my KIRKEY RACING seat accept different styles of safety belts?

Our standard seats are designed to be used with 5 point safety belts. The more advanced seats (47/53/56/58/63/66/67/68 series) will accommodate the 6 point belts. Regardless of the manufacturer these belts styles should work just fine. Always follow manufacturer directions for installing safety belts.

I was in an accident and my KIRKEY RACING seat is bent, what should I do?

If the seat is bent, wrinkled, separated or in any way deformed then it should be replaced, the structure of the seat has been compromised. Using a seat that is deformed will only increase your risk of injury.

Will my seat work with the HANS® device?

The Full Containment seats (53/63/66/67/68 series) have been designed to accommodate the HANS® device and other types of head and neck restraints.

For complete FAQ's please visit our website
www.kirkeyracing.com



WARRANTY DISCLAIMER

KIRKEY RACING FABRICATION, INC. manufactured and/or distributed the enclosed components for use on vehicles designed and built by persons not associated or controlled by **KIRKEY RACING FABRICATION, INC.** No specific use is recommended, intended or contemplated. Because some environments may subject components to severe stress, and because components are affected by many forces beyond the foreseeability and control of **KIRKEY RACING FABRICATION, INC.**, **THESE PRODUCTS ARE SOLD WITHOUT WARRANTY OF MERCHANTABILITY OR OF FITNESS FOR ANY PURPOSE. NO WARRANTY EXPRESSED OR IMPLIED ACCOMPANIES THESE PRODUCTS AND THE PURCHASER AND/OR USER, HAVING INSPECTED THESE COMPONENTS, MAKES THE SOLE DETERMINATION OF THEIR SUITABILITY FOR USE IN AN APPLICATION OF HIS OR HER OWN DESIGN.** By the installation of these components, the user or installer assumes all risks of damage, injury or death.



P.O. Box 70, St. Andrew's West, Ontario, Canada K0C 2A0
Telephone: 613 938-4885 • Fax: 613 938-6367
In USA: P.O. Box 445, Rooseveltown, NY 13683
kirkey@kirkeyracing.com • www.kirkeyracing.com

DISTRIBUTED BY