

# RAGE

POWERSPORT PRODUCTS

# TABLE OF CONTENTS

- Motorcycle Products..... 3
  - › Motorcycle Ramps.....3
  - › Motorcycle Hitch Carriers.....7
  - › Motorcycle & MX Bike Stands.....8
  - › Tie Downs, Chocks & Covers ..... 10
- ATV Products ..... 12
- Lawn & Garden Ramps..... 15
- ATV Basket, Boxes & Accessories 16
- Cargo Products ..... 17
- Cargo Products ..... 18
- Premium Bike Racks/ Carriers .....20
- Bike Racks/ Carriers .....22
- Pet Products.....23
- Heavy Duty Ramps .....25

Contact Us:

## RAGE POWERSPORT PRODUCTS

1402 South Elliott  
Aurora, MO 65605

Phone: 800-851-6396

Fax: 314-754-8180

Email: sales@ragepowersports.com

Rage Powersports Products manufactures, sources and distributes products for loading, hauling and transporting.

Our lineup of products is one of the most diversified in the industry and is available in the US and Canada at fine retailers that serve the Powersports, Heavy Duty Equipment, Mobility, Pet and Bicycle markets.

The promise we make to our dealers. We promise...

## GOODS

... to continue to develop and expand the product line with innovative features.

## PROFITS

... to offer you value and profit opportunities to help grow your bottom line.

## SERVICE

... to provide you with a level of service to expand your customer base.

**HUGE SELECTION OF ATV, MOTORCYCLE & CARGO GEAR**  
**GREAT DEALER MARGINS ON ALL PRODUCTS**  
**PRODUCTS SHIP DAILY FROM MULTIPLE LOCATIONS**  
**NO MINIMUM ORDER SIZES - DROP SHIPPING OFFERED**  
**LOWEST DEALER PRICE ANYWHERE ON RAMPS**

FIND OUT WHY AMERICA'S MOST SUCCESSFUL RETAILERS RUN WITH



# MOTORCYCLE PRODUCTS

## BIG BOY II MOTORCYCLE RAMP

The Big Boy 2 loading ramp is by far the most innovative ramp system to hit the market! Packed full of features allowing you to load not just motorcycles, but ATV's, golf carts, UTV's, zero turn lawn mowers or just about any pneumatic wheel vehicle up to 2500 lbs.! The Big Boy 2 is constructed of lightweight, rustproof aluminum & consists of 2 separate single runner ramps that can be connected together with (4) included connecting brackets. The ramp system can be folded in half at the center for storage, & when unfolded, features a 12° offset for greater clearance for lower vehicles.

### THE NEXT GENERATION **Big Boy II** 2 PIECE RAMP SYSTEM

The Big Boy II comes in 10 or 12 foot length to meet most loading height requirements & is 38 inches wide when both ramps are connected together (19" wide per ramp). The whole system only weighs 86 lbs. Each Big Boy 2 includes 2 cam buckle straps for loading safety & a 5 year manufacturers warranty! Made in the USA!



#### APPLICATIONS:

Load all types of pneumatic wheeled vehicles up to 2500 lbs. into pick up trucks or trailers.

#### FEATURES:

- » Weighs only 86 lbs.
- » Consists of 2 single runner ramps
- » Connect the 2 ramps together with (4) included connecting brackets
- » Serrated cross rungs for maximum traction
- » 2 Cam buckle safety straps
- » Full width plate style attaching lip
- » 2500 lb. weight capacity (1250 PER SECTION)
- » Lightweight, rust proof aluminum construction
- » Designed for 1 person loading & unloading
- » 5 year manufacturer warranty

⚠ Always connect & Pin H brackets when loading motorcycles



## BLACK WIDOW MOTORCYCLE RAMP

The Black Widow motorcycle loading ramp system is an aluminum, multi-purpose, heavy duty aluminum ramp system that works for motorcycles, Atv's, tractors, or just about anything that needs loading.

The Black Widow is a full 40 inches wide when bolted together & is available in 2 lengths to accommodate most loading heights. This ramp has 3 heavy duty sections which can each be used separately or can all be bolted together for one rock solid system. This extra wide system makes loading a motorcycle with one person a snap. This system is an indispensable tool to the user who owns multiple recreational vehicles that need loading but does not want to spend a fortune on multiple systems.



#### APPLICATIONS:

Load motorcycles or four-wheeled machinery with average clearance into small, mid-sized & 4x4 trucks & most trailers with ease.

#### FEATURES:

- » Fold to half their length for easy storage & transport
- » Ramps bolt together for added strength for loading heavier bikes
- » Lightweight all aluminum design w/ black powder coat
- » Designed to walk up or ride bike up & down
- » 2700 lb. total capacity (1500 lb. for center section- 600 lb. for each side section)
- » Arched design to increase clearance
- » Serrated cross rungs for maximum traction
- » 3 heavy duty 1" wide cam buckle safety straps
- » Full width plate style attaching lip
- » Designed for 1 person loading & unloading
- » 5 year manufacturer warranty



⚠ Bolting the ramps together with supplied long bolts is recommended for loading motorcycles

Model	<b>MF2-12038</b> THE BIG BOY	<b>MF2-14438</b> THE BIG BOY
Length	120" or 10'	144" or 12'
Width	38" Total 19" per section	38" Total 19" per section
Folded Length	60.5"	72.5"
Weight (Total)	86 lbs.	100 lbs.
Weight Capacity	2500 lbs. 1250 lbs. per section	2000 lbs. 1000 lbs. per section

Model	<b>BW-9440</b>	<b>BW-10840</b>
Length	94" or 7'10"	108" or 9'
Width	40" Total Center=17.25" Sides=11.25"ea	40" Total Center=17.25" Sides=11.25"ea
Folded Length	48.5"	54.5"
Weight (Total)	92 lbs.	106 lbs.
Weight Capacity	2700 lbs. Total 1500 lbs. center section 600 lbs. per side section	2700 lbs. Total 1500 lbs. center section 600 lbs. per side section

**THE ORIGINAL BIG BOY MOTORCYCLE RAMP**

Our full size folding motorcycle loading ramps are the Cadillac of the loading ramp industry. This motorcycle ramp system gives you the freedom to load & unload a medium sized or large motorcycle safely with one person. These aluminum ramps are the lightest full size motorcycle loading ramps on the market today.

These high quality arched motorcycle loading systems are available in 2 lengths to meet most loading height requirements & have a total of 38 inches of width to allow the rider to put their feet down. The arched design prevents bottoming out of the motorcycle. These ramps fold in half to fit right next to the motorcycle or break down to 3 sections that fold in half in seconds with the removal of the connecting rod that connects the 3 separate sections together for compact storage even in the truck cab.



**APPLICATIONS:**

Load motorcycles with average clearance into small, mid-sized & big 4x4 trucks & most trailers with ease.

**FEATURES:**

- » Weighs in at only 68 lbs., the lightest full-size motorcycle ramp anywhere!
- » All Aluminum (T6-6061) construction will provide years of rust free use
- » Break apart into 3 sections that fold for compact storage
- » Serrated cross rungs for maximum traction
- » 2 heavy duty 1" wide cam buckle safety straps
- » Full width plate style attaching lip
- » 1500 lb. weight capacity
- » Designed for 1 person loading & unloading

⚠ Motorcycle Use Only- Connecting Rod must be inserted through all 3 ramps before use, Ramps cannot be used individually

Model	Length	Width	Folded Length	Weight	Weight Capacity
<b>MF-12038</b>	120" or 10'	38" Total Center=14" Sides=12"ea	60.5	68 lbs.	1500 lbs. (Connected)

**HEAVY DUTY FOLDING RAMP SYSTEM**

Use these heavy duty folding ramps to load motorcycles, ATV's, UTV's & tractors. The ramp system is constructed of aluminum & can be separated into dual ramps or connected for a solid 38" wide ramp. A built in offset arch in the ramps provide extra clearance for lower bikes or ATV's. Extra heavy duty serrated plates replace the standard rung design. There are three lengths available with varying weight capacity's from 2000 lbs. to 3000 lbs. These heavy duty ramps include safety straps to keep secured to the loading surface. Designed for 1 person loading & unloading. Quality built in the USA!

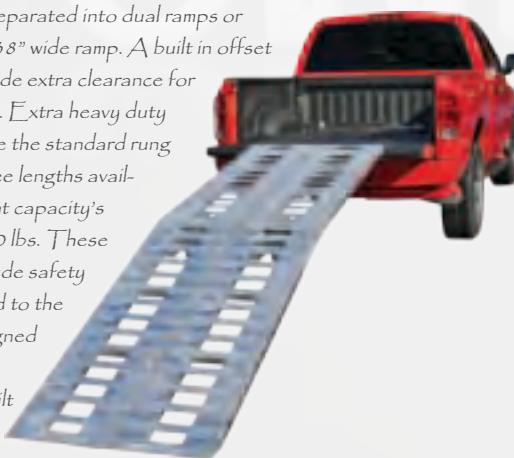

**BLACK WIDOW XL - EXTRA LONG**

Load a low clearance motorcycle into a pick up truck or trailer with the Black Widow Extra Long Motorcycle Ramp. This ramp is designed for easy one person loading & unloading. The extra long design allows for loading into taller trucks or trailers & the arched design provides the clearance needed to load lowered bikes. The ramp system is constructed of aluminum with a black powder coated finish.

This extra long ramp folds in the middle for storage when transporting & can be taken apart into 6 compact sections for long term storage. Each ramp section bolts together & has connecting brackets to distribute the weight for stability. The Black Widow XL ramp is available in 2 lengths for your specific application. Include 3 safety straps.

**APPLICATIONS:**

Load motorcycles with lower clearance into 4x4 trucks, Box Trucks, Toy Haulers & trailers.

**FEATURES:**

- » Fold to half their length for easy storage & transport
- » Breaks down into 6 sections for long term storage
- » Ramps bolt together for added strength for loading heavier bikes
- » Lightweight all aluminum design w/ black powder coat
- » Designed to ride bike up & down
- » Model# BW-12040: 2000 lb. total capacity
- » Model# BW-14440: 1500 lb. total capacity
- » Arched design to increase clearance
- » Serrated cross rungs for maximum traction
- » (3) heavy duty 1" wide cam buckle safety straps
- » Full width plate style attaching lip
- » Designed for 1 person loading & unloading

⚠ Motorcycle Use Only- All 3 sections must be bolted together with supplied hardware while Loading & unloading

Model	Length	Width	Folded Length	Weight	Weight Capacity
<b>BW-12040</b>	120" or 10'	40" Total Center=17.25" Sides=11.25"ea	60.5	106 lbs.	2000 lbs. (Connected)
<b>BW-14440</b>	144" or 12'	40" Total Center=17.25" Sides=11.25"ea	72.5	136 lbs.	1500 lbs. (Connected)

**FEATURES:**

- » Available in 3 lengths
- » Load motorcycles or ATV's by yourself
- » All aluminum construction - lightweight - rust proof
- » Solid plate attaching lip
- » Extra wide plate style serrated rungs offer maximum traction in the rain, mud or snow. Stronger than the traditional "rung" design.
- » Heavy duty hinge system folds in half for storage
- » Use together as a solid ramp or spread apart as dual runners
- » Includes safety straps to tie down to the loading surface

Model	Length	Width	Folded Length	Weight	Weight Cap
<b>HD-12038-3000</b>	120" or 10'	38" Total 19" per section	60.5"	112 lbs 56 lbs. ea	3000 lbs. 1500 lbs. per section
<b>HD-14438-2500</b>	144" or 12'	38" Total 19" per section	72.5"	130 lbs 65 lbs. ea	2500 lbs. 1250 lbs. per section
<b>HD-16838-2000</b>	168" or 14'	38" Total 19" per section	84.5"	160 lbs 80 lbs. ea	2000 lbs. 1000 lbs. per section



### FOLDING MOTORCYCLE TRAILER RAMP

The TF-6050 is a Tri-Folding motorcycle trailer ramp for loading a bike onto open & enclosed trailers. This ramp has a full width attaching lip to fit on almost any trailer & folds to 1/3rd its width so it can be easily stored on any trailer. The 50" of width allow the rider to put their feet down when loading. The heavy duty center takes a bike up to 1500 lbs. & the ramp also can load Atvs, small garden tractors & more.

#### FEATURES:

- » Folds down to 17" wide for compact storage
- » Wide enough to put feet down, designed to ride up
- » Works for motorcycles, ATVs, garden tractors & more
- » 50" wide full attaching lip
- » All Aluminum construction
- » 2 heavy duty 1" cam buckle safety straps
- » Designed for 1 person loading & unloading
- » 1500 lb. weight capacity
- » Serrated rungs for maximum traction



Model	Length	Width	Folded Width	Weight	Weight Capacity
<b>TF-6050-1500</b>	60" / 5'	50"	17"	32 lbs.	1500 lbs.

### 90" LONG 3 PIECE RAMP

The AF-9034-HD 3 piece ramp system is a combination of our heavy duty 90" single ramp & our AFP solid plate Atv ramps plus a hardware connecting kit. This 3 piece system is 90" long & is perfect for loading bikes onto small 4x2 trucks & trailers. This system is rock solid when bolted together & has a solid surface on the side section to put your feet down when riding up or down.

The 1500 lb. capacity center section & the side sections can be un-bolted & used separately as well for just about any loading job. All 3 sections fold in half & can be stored together or separately.



#### FEATURES:

- » All 3 sections fold in half & come apart
- » Center & side sections can be used separately for atv's, lawn equipment, & more
- » All Aluminum construction w/ solid side sections for feet
- » 3 heavy duty 1" cam buckle safety straps
- » Includes all hardware for every possible configuration
- » Designed for 1 person loading & unloading
- » 1500 lb. center ramp, 750 lb. per side section

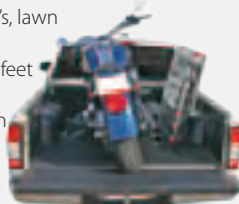

Model	Length	Width	Folded Length	Weight	Weight Capacity
<b>AF-9034</b>	90" / 7'6"	34"	46"	56 lbs.	1500lb. Center 750 lb. Sides

### 3 PIECE NON-FOLDING MOTORCYCLE RAMP

#### All New Wider Design

These full size non-folding motorcycle ramps are loaded with features for quick loading. This motorcycle ramp system gives you the freedom to load & unload a medium sized or large motorcycle safely with one person. These high quality arched motorcycle loading systems are available in 2 length's & now have a total of 40 inches of width to allow the rider more room to put their feet down.



These ramp systems are ideal for trailers where storage space is not a problem & both models will fit into an 8 foot bed next to the motorcycle with the tailgate up.

#### APPLICATIONS:

Load motorcycles or four-wheeled machinery with average clearance into small, mid-sized & 4x4 trucks & most trailers with ease.

#### FEATURES:

- » Full width plate style gripping edge
- » Arch helps prevent bottoming out of motorcycle
- » 1.5 inch raised ramp edges that act like curbing
- » Serrated rungs at a spacing of 3" for superior traction
- » User friendly adjustable safety straps
- » Durable all aluminum (T6 - 6061) construction will provide for many years of non-rusting safe use
- » 5 year warranty

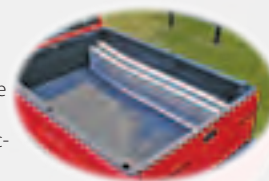

Model	Length	Width	Weight	Weight Capacity
<b>M-8440</b>	84" or 7'0"	40" Total Center=16" Sides=12"ea	46 lbs.	2700 lbs. Total 1500 lbs. center section 600 lbs. per side section
<b>M-9540</b>	95" or 7'11"	40" Total Center=16" Sides=12"ea	52 lbs.	2700 lbs. Total 1500 lbs. center section 600 lbs. per side section

### BLACK WIDOW SINGLE MOTORCYCLE RAMP

The Black Widow single folding motorcycle ramp is a 17" wide motorcycle loading ramp that folds to half it's length for compact storage. The extra width of this single loading ramp makes it much more forgiving than most single runner ramps when pushing up a street bike or off road bike.



#### FEATURES:

- » Folds in half for storage & transport
- » Extra wide design is more forgiving when pushing a bike up
- » All aluminum with black powder coat
- » Arched design to increase clearance
- » Serrated cross rungs for maximum traction
- » Heavy duty 1" wide cam buckle safety strap
- » Full width plate style attaching lip
- » 1500 lb. weight capacity
- » 5 year manufacturer warranty



Model	Length	Width	Folded Length	Weight	Weight Capacity
<b>BW-9417</b>	94" or 7'10"	17.25"	48.5"	48 lbs.	1500 lbs.
<b>BW-10817</b>	108" or 9'	17.25"	54.5"	56 lbs.	1500 lbs.

### ALUMINUM FOLDING MOTOCROSS RAMP

Aluminum Folding Motocross ramps have a solid plate lip for added stability, raised sides and a unique tread design to prevent tires from slipping during loading and unloading. Each ramp has a maximum weight capacity of 400 lbs, can be folded to a compact 2-1/2" x 41" and easily carried with a plastic handle, or secured to a truck bed with an adjustable strap.

**FEATURES:**

- » Folds exactly in half
- » Attached Carrying Handle
- » Lightweight non-rust aluminum construction
- » Raised safety edges
- » Solid attaching lip plate
- » Adjustable safety straps included
- » Maximum Capacity of 400 lbs.
- » 1 Year Warranty



Model	Length	Width	Folded Length	Weight	Weight Capacity
<b>DBF-8206</b>	82" / 6'10"	6"	41"	8 lbs.	400 lbs.

### ALUMINUM NON-FOLDING MOTOCROSS RAMP

Non folding version of our aluminum motocross ramp. Raised edges, a raised tire grip, and a solid lip plate ensure maximum stability during use. Includes adjustable safety strap.

**FEATURES:**

- » Lightweight non-rust aluminum construction
- » Raised safety edges & solid attaching lip
- » Adjustable safety straps included
- » Maximum Capacity of 400 lbs.
- » 1 Year Warranty

Model	Length	Width	Weight	Weight Capacity
<b>DB-7606</b>	76" / 6'4"	6"	6 lbs.	400 lbs.



### LIGHT DUTY SINGLE FOLDING MOTORCYCLE RAMP

Our light duty single folding motorcycle ramps are designed for loading off road & motocross bikes. These ramps are available with rungs or plate style solid surface. They are all aluminum & fold in half for compact storage.

**FEATURES:**

- » Folds in half for storage & transport
- » Lightweight All aluminum Arched design
- » Serrated cross rungs for maximum traction
- » Heavy duty 1" wide cam buckle safety strap
- » Rubber coated fingers protect tailgate



Model	Length	Width	Folded Length	Weight	Weight Capacity
<b>AFL-9012</b>	90" / 7'6"	11.25"	45"	14.5 lbs.	550 lbs.
<b>AFP-9012 (Plate Style)</b>	90" / 7'6"	11.25"	45"	16 lbs.	750 lbs.

### ECONOMY ARCHED MOTOCROSS RAMP

This economical arched motocross bike ramp is perfect for the weekend warrior on a budget. Just the basics in this ramp which is what some customers prefer. Super light weight all aluminum design.

**FEATURES:**

- » Lightweight All aluminum with 600ww lb. weight capacity
- » Arched design to increase clearance
- » Serrated cross rungs for maximum traction & 3" rung spacing
- » Heavy duty 1" wide cam buckle safety strap
- » Rubber coated fingers protect tailgate

Model	Length	Width	Weight	Weight Capacity
<b>IA-9012</b>	90" / 7'6"	12"	14 lbs.	600 lbs.

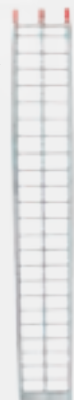

### SINGLE HD FOLDING MOTORCYCLE RAMP

The AF-9012-HD is a single 90" long folding motorcycle loading ramp with a heavy duty 1500 lb. capacity to easily load any size bike from a small dirt bike to a large cruiser.



**FEATURES:**

- » Folds in half for storage with heavy duty hinge system
- » Lightweight All aluminum arched design to increase clearance
- » Serrated cross rungs for maximum traction
- » Heavy duty 1" wide cam buckle safety strap
- » Full width plate style attaching lip
- » 1500 lb. weight capacity
- » 1 year warranty

Model	Length	Width	Folded Length	Weight	Weight Capacity
<b>AF-9012-HD</b>	90" / 7'6"	11.25"	45"	24 lbs.	1500 lbs.

### NON-FOLDING SINGLE MOTORCYCLE RAMPS

These single 12" & 16" wide motorcycle ramps are the perfect solution for loading small & medium sized bikes onto low pick up trucks or trailers. With the help of an assistant a motorcycle can easily be pushed up the runner for quick loading. These ramps include raised & beveled side rails to help keep the bike on course, a full width attaching lip & an aggressive serrated rung traction surface for superior tire grip



**FEATURES:**

- » 1.5" raised ramp edges act like curbing to keep the bike on track
- » Full width plate style gripping edge w/ rubber pads
- » Arch helps prevent bottoming out or scraping of machinery
- » Serrated rungs at a spacing of 3" with an aggressive non-skid surface
- » Heavy duty 1" wide cam buckle safety strap
- » Durable all aluminum (T6 - 6061) construction will provide for many years of non-rusting safe use
- » 5 year manufacturer warranty

Model	Length	Width	Weight	Weight Capacity
<b>M-8412-600</b>	84" or 7'	12"	15 lbs.	600 lbs.
<b>M-8416-1500</b>	84" or 7'	16"	22 lbs.	1500 lbs.
<b>M-8912-900</b>	89" or 7'-5"	12"	18 lbs.	900 lbs.
<b>M-9512-600</b>	95" or 7'-11"	12"	19 lbs.	600 lbs.
<b>M-9516-1500</b>	95" or 7'-11"	16"	24 lbs.	1500 lbs.

### ALUMINUM HITCH MOTORCYCLE CARRIER

Our aluminum motorcycle carrier mounts right into a class III, IV or V 2 inch diameter receiver hitch. This device can carry up to a 400 lb. motocross bike without the need for a trailer or even a pick up truck. This all aluminum design is both economical & light in weight. The system includes a loading ramp & also a anti-tilt locking device to prevent sway of the carrier when it is loaded. The runged surface has a 16" opening for the front tire to simply drop into & included attaching points to tie down the bike with straps.



#### FEATURES:

- » Lightweight all aluminum design
- » Fits in any 2 inch receiver
- » Includes aluminum loading ramp
- » Loading ramp attaches to carrier when traveling
- » Carries up to a 400 lb. motorcycle
- » 2 integrated tie down loops
- » Assembles in seconds



Model	Track Length	Track Width	Ramp Length	Weight	Weight Capacity
<b>AMC-400</b>	75"	5.5"	45"	36 lbs.	400 lbs.

### ALUMINUM HITCH MOTORCYCLE CARRIER

Load up & haul 2 dirt bikes with our hitch mounted double motorcycle carrier. The AMC-600-2 is constructed of aluminum with a steel powder coated main hitch tube for added support. An included ramp is used to load up bikes, & when not in use, the ramp secures to the carrier. Included with the hitch mounted carrier is a anti-tilt device for extra stability. The carrier can attach to 2" square class III, IV, V hitch receivers.



#### FEATURES:

- » Lightweight all aluminum design
- » Fits in any 2 inch receiver
- » Includes aluminum loading ramp
- » Loading ramp attaches to carrier when traveling
- » Carries up to a 600 lbs.
- » 2 integrated tie down loops
- » Designed for dirt bikes or motocross bikes



Model	Track Length	Track Width	Ramp Length	Weight	Weight Capacity
<b>AMC-600-2</b>	75"	5.5"	45"	69 lbs.	600 lbs.

### STEEL HITCH MOTORCYCLE/SCOOTER CARRIER

Transport a dirt bike or a scooter with this heavy duty 600 lb. capacity motorcycle carrier. The MX-600 carrier is constructed of steel & has a black powder coated finish for protection. The carrier will fit into a 2" class III or greater receivers & can safely carry 600 lbs. Included with this carrier is a 5' long loading ramp which attaches to the carrier when not in use. The carrier features integrated loops for tie down straps & removable pins to adjust the size of the front wheel channel from 8"-12" for either a scooter or dirt bike. Also included is an anti-tilt device & pinch bolt to eliminate carrier wobble.



#### FEATURES:

- » Durable steel frame with black powder coating
- » Fits in any 2 inch receiver
- » Includes 5' loading ram
- » Loading ramp attaches to carrier when traveling
- » Front tire cradle adjusts from 8"-12" for dirt bikes or scooter
- » Carries up to 600 lbs.
- » 2 integrated tie down loops
- » Pinch bolt removes receiver slack
- » Designed for dirt bikes or scooter

Model	Track Length	Track Width	Ramp Length	Weight	Weight Capacity
<b>MX-600</b>	76.75"	5.5"	60"	62 lbs.	600 lbs.

### SPORT MOTORCYCLE CARRIER

The SMC-600 sport bike motorcycle carrier is designed to transport motorcycles up to 600 lbs. on a 2" class III or greater hitch receiver. The carrier features a 72" long ramp for loading up bike & an integrated wheel chock for front wheel stability. Durable, yet lightweight, the carrier frame is constructed of black powder coated steel while the carrier track is constructed of aluminum. An included anti-tilt device keeps the carrier stable.



#### FEATURES

- » Durable steel black powder coated frame
- » Aluminum carrier track
- » Fits in any 2 inch class III or greater receiver
- » Includes 6' loading ramp
- » Loading ramp attaches to carrier when traveling
- » Carries up to 600 lbs.
- » Integrated wheel chock for added motorcycle stability
- » Anti-tilt device included for carrier stability
- » Only Weighs 85 lbs.



Model	Track Length	Track Width	Ramp Length	Weight	Weight Capacity
<b>SMC-600</b>	78.75"	8"	72"	85 lbs.	600 lbs.

# Black Widow

## PROFESSIONAL GRADE MOTORCYCLE STAND SERIES

### BLACK WIDOW REAR MOTORCYCLE STANDS

The Black Widow Professional Grade motorcycle stands are designed for lifting the rear of a motorcycle for service, maintenance, or storage. The stands are constructed of 1-1/4" steel tubing with a durable black powder coat. There are 2 models available: BW-12 is designed to fit on rear swing arms, & BW-14 is designed to fit on motorcycles with rear spools. Each stand only weighs 10 lbs. making it easy to take to the track or shop.

**BW-14**



**BW-12**



**FEATURES:**

- » Up to 14 inch lift height
- » 3" heavy duty casters
- » 1.25" steel tubing construction
- » Elevated rear handle for easy lifting
- » Black powder coated finish
- » Universal design For spools(BW-14) or swingarms(BW-12)
- » Easy 1 person operation lifts a bike in seconds

Model	Swing arm Fitting	Weight
<b>BW-12</b>	Fits Swingarms 10-13.5" Wide	10 lbs.
<b>BW-14</b>	Fits Spools 9"-14" Wide	10 lbs.

### MOTORCYCLE BED RACK FOR TRUCK BEDS

Take down 1 or 2 motorcycles for transportation in the back of a pickup truck with the adjustable 54"-74" wide Motorcycle Bed Rack, featuring a durable all-steel construction, three tie-down points and two wheel chocks for optimal stabilization. Comes with all necessary hardware for mounting and installation requires drilling. To add 3 motorcycles the optional center chock is available.

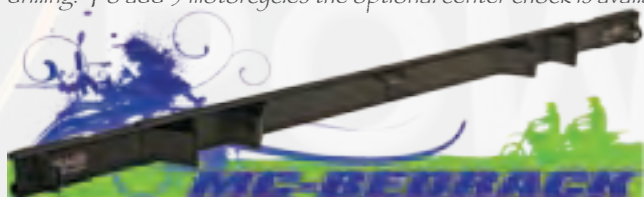

**FEATURES:**

- » Overall adjustable 54" to 74" wide
- » Heavy duty tie rings
- » Two Integrated Wheel Chocks
- » Optional 3rd motorcycle center extension available
- » All steel construction with Black powder coat
- » Includes all mounting hardware
- » Assembly requires drilling
- » 1 Year Warranty

Model	Description	Weight
<b>MC-BEDRACK</b>	Adjustable Motorcycle Bed Rack Adjusts from 54"-74" wide	10 lbs.
<b>MC-BEDRACK-EXT</b>	Center Mount Chock Extension for the MC-BEDRACK	4 lbs.

### BLACK WIDOW FRONT MOTORCYCLE STANDS

Black Widow Professional Grade motorcycle stands are great for use at the shop, in the garage, or at the track. 2 different styles are available for lifting the front of a motorcycle for service or maintenance. Each stand is constructed of heavy duty steel tubing with a durable black powder coat. (4) 3" wheels make for a smooth lifting motion. Stands only weigh 8 lbs.

**BW-06**



**BW-10**



**FEATURES:**

- » 3" heavy duty casters
- » Black powder coated finish
- » 1.25" steel tubing construction
- » Universal design for front motorcycle forks
- » Elevated rear handle for easy lifting
- » Easy 1 person operation lifts a bike in seconds

Model	Adjustable Width	Lift Height	Weight
<b>BW-06</b>	6-1/2" to 9-3/4"	2-5" (varies per tire)	8 lbs.
<b>BW-10</b>	6" to 10"	2-4" (varies per tire)	8 lbs.

### COLOR REAR SWING ARM STANDS

The standard rear swing arm motorcycle stands are available in 4 colors to match the most popular sport bike factory colors. These rear swing arm stands feature reversible rubber mounts & optional spool attachments adjustable from 8"-13 1/5" wide for street or race bikes. 3" wheels and 1.5" tube construction round out this rugged design for years of use at the shop or the track.



**FEATURES:**

- » Thick 1.5" tubing available
- » 4 wheels with 3" diameter
- » Red, Blue, Green & Yellow available
- » Lightweight at 10lbs.
- » Reversible rubber mounts & spool attachments included

Model	Color	Weight
<b>MC-STAND-B</b>	Blue	10 lbs.
<b>MC-STAND-R</b>	Red	10 lbs.
<b>MC-STAND-Y</b>	Yellow	10 lbs.
<b>MC-STAND-G</b>	Green	10 lbs.



### FOOT PEDAL OPERATED MOTOCROSS BIKE STAND

This lifting stand is designed to lift motocross & dirt bikes up of to 15" with a 4.5" lifting range. The stand offers sturdy steel construction with easy to use lifting pedal. The wide base provides a sturdy foundation for service or maintenance. The platform has dimensions of 8.25" x 11" with a rubber contact pad & makes lifting a bike with 1 person quick & easy.



**FEATURES:**

- » 1.25 powder coated steel tube Construction
- » Quick raise foot pedal operation
- » 15" max height & a 4.5" lifting range
- » Lightweight at 10 lbs.
- » 8.25" x 11" rubber coated platform
- » Universal design lifts MX bikes up to 350 lbs.

Model	Max Height	Weight Capacity	Weight
<b>MX-STAND-2</b>	15"	350 lbs.	10 lbs.

### DELUXE FOOT PEDAL OPERATED BIKE STAND

The deluxe motocross stand is designed to lift motocross & dirt bikes up off the ground up to 16.5" with a 2.75" lifting range. The stand is constructed of red anodized aluminum with an easy to use lifting pedal. The cross bar base provides a sturdy foundation for servicing or maintaining a bike. The platform has dimensions of 6.5" x 10" & the foot pedal is 10" long.



**FEATURES:**

- » Constructed of lightweight anodized aluminum
- » Quick raise foot pedal operation
- » 6.5" max height & a 2.75" lifting range
- » Weighs 8 lbs.
- » 6.5" x 10.5" platform
- » Sturdy cross bar base

Model	Max Height	Weight Capacity	Weight
<b>MX-STAND-DLX</b>	16.5"	350 lbs.	8 lbs.

### FOLDING MOTOCROSS BIKE STAND

The folding motocross stand is designed for service of motocross bikes & includes a 6 quart drain pan. The stand folds up for minimal storage size or to hang up in a shop or trailer & includes a carrying handle. Lifts the bike to 14.25" & has a rubber coated base platform.



**FEATURES:**

- » Yellow powder coated Sturdy steel Construction
- » Folds for storage & includes carrying handle
- » 20" Long x 15.25" Wide x 14.25" High
- » Rubber coated 10" x 11.25" platform
- » Includes 6 quart oil drain pan
- » Tool tray & hole for oil draining

Model	Dimensions	Weight Capacity	Weight
<b>MX-STAND-DLX-FOLD</b>	14.25"H x 15.25"W x 20"L	350 lbs.	8 lbs.

### ALUMINUM MOTOCROSS STANDS

Use the aluminum motocross stands for storing, servicing, or maintaining dirt bikes or motocross bikes. These stands are constructed of polished aluminum making them lightweight & easy to setup. The top platform measures 9" x 9" diameter & has a gas & oil resistant rubber pad riveted on. A removable tray located underneath the stand can be used to store parts, tools, or used to catch used oil when doing oil changes on the larger stand. A 3.75" square opening is also provided to allow oil to flow from the bike crankcase to the oil drain pan. The stand has a total height of 16.5" high.



**FEATURES:**

- » Constructed of lightweight polished aluminum
- » Raises bikes up 16.5"
- » Weighs 8 lbs.
- » 9" x 9" rubber covered top
- » Removable tray for parts or tools
- » 3.75" square opening allows oil to flow to the oil drain pan

Model	Dimensions	Weight Capacity	Weight
<b>MX-STAND-ALUM</b>	16.5"H x 17.25"W x 15.5"L	350 lbs.	8 lbs.
<b>MX-STAND-ALUM-LITE</b>	16.5"H x 15.25"W x 14.25"L	350 lbs.	8 lbs.

### STEEL & ALUMINUM MOTOCROSS LIFTS

Our Motocross Lift series is available in both steel or aluminum models and are designed to lift a MX bike up to 36". These lifts bring a bike up to the height to allow work to be done on them in the standing position & also allow for taking the weight off of the suspension for off season storage. Both models are foot pedal operated, lift up to a 300lb bike & include devices to secure the bike to the lift.. Locking mechanism for the extended position.



**FEATURES:**

- » Available in steel or lightweight aluminum construction
- » Easy to operate foot pedal
- » Rubber pad on surface with opening for draining oil
- » Both lifts include attaching devices to secure bike to lift
- » Lifts bike up to 36" to allow service from standing position & storage.
- » Locking device to lock in the extended position

Model	Dimensions (Not raised)	Lifting Range	Weight Capacity	Weight
<b>MX-LIFT</b>	13.75"H x 17"W x 19"L	13.75-35.25" High	300 lbs.	68 lbs.
<b>MX-LIFT-ALUM</b>	15"H x 16.25"W x 18.25"L	15-36" High	300 lbs.	50 lbs.

# Major ease of the Down Kits



## 8 PIECE 1" MOTORCYCLE STRAP KITS

Our professional grade motorcycle tie down kits consist of premium quality, 1" webbing 6' long straps & heavy duty ratchet & cam buckle mechanisms. All our kits also include four 12" soft loops which avoid the strap hooks from coming in contact with the motorcycle.



### FEATURES:

- » Heavy duty 3000 lb. break strength ratchet straps
- » Heavy duty 1500 lb. break strength cam buckle straps
- » Huge 5" vinyl coated S-hooks
- » Looped ends for leverage when tightening
- » 1" wide by 12" long soft loops to prevent contact of hooks with the bike
- » HEAVY DUTY oversized cam buckles & ratchets

Model	Includes
<b>MCSK1</b>	(2) 1" cam-buckle straps (2) 1" ratchet straps (4) Soft Loops
<b>MCSK1-R</b>	(4) 1" ratchet straps (4) Soft Loops
<b>MCSK1-C</b>	(4) 1" cam-buckle straps (4) Soft Loops



## EVERY CUSTOMER WHO PURCHASES A RAMP OR LOADING ACCESSORY FROM YOU SHOULD BE OFFERED THESE HIGH QUALITY STRAP KITS AS AN ADD ON

Too many riders today are securing their motorcycles with cheap, light duty straps. Every one of our motorcycle products can utilize one of these tie down packages so we encourage all of our dealers to stock these kits for a quick & easy up-sell.

## 8 PIECE 2 INCH MOTORCYCLE STRAP KITS

Our professional grade Super Duty 2" motorcycle tie down kits consist of premium quality, 2" webbing 6' long straps & heavy duty ratchet & cam buckle mechanisms. All our kits also include four 12" soft loops which avoid the strap hooks from coming in contact with the motorcycle.



### FEATURES:

- » Heavy duty 4400 lb. break strength ratchet straps
- » Heavy duty 3000 lb. break strength cam buckle straps
- » Huge 5" vinyl coated S-hooks
- » Looped ends for leverage when tightening
- » 1" wide by 12" long soft loops to prevent contact of hooks with the bike
- » HEAVY DUTY oversized cam buckles & ratchets

Model	Includes
<b>MCSK2</b>	(2) 2" cam-buckle straps (2) 2" ratchet straps (4) Soft Loops
<b>MCSK2-R</b>	(4) 2" ratchet straps (4) Soft Loops
<b>MCSK2-C</b>	(4) 2" cam-buckle straps (4) Soft Loops

## 8 PIECE 2" SNAP HOOK STRAP KITS

Our professional grade Super Duty 2" snap hook tie down kits have spring loaded locking snap hooks on the ends for the most secure connection possible. These are the tie down kits for the biker who takes securing his motorcycle seriously & knows he has a lot to lose if not done correctly. 2" webbing 6' long straps & heavy duty ratchet & cam buckle mechanisms. These kits also include four 12" soft loops which avoid the strap hooks from coming in contact with the motorcycle.

### FEATURES:

- » Heavy duty 4400 lb. break strength ratchet straps
- » Heavy duty 3000 lb. break strength cam buckle straps
- » Spring loaded snap hook ends
- » Looped ends for leverage when tightening
- » 1" wide by 12" long soft loops to prevent contact of hooks with the bike
- » HEAVY DUTY oversized cam buckles & ratchets

Model	Includes
<b>MCSK-SH</b>	(2) 2" cam-buckle snap-hook straps (2) 2" ratchet straps (4) Soft Loops
<b>MCSK-SH-R</b>	(4) 2" ratchet snap-hook straps (4) Soft Loops
<b>MCSK-SH-C</b>	(4) 2" cam-buckle snap-hook straps (4) Soft Loops

## REMOVABLE MOTORCYCLE WHEEL CHOCK KITS

These high quality removable motorcycle wheel chocks kits include hardware that can be bolted into a trailer floor or pickup truck bed & allow the chock to be quickly removed when not needed.

These chocks are constructed of heavy duty 1 inch steel tubing & are powder coated black. 3 sizes are available to fit a everything from a dirt bike, street bike to a wide tire drag bike.



### FEATURES:

- » Can be installed or removed quickly with included mounting kit
- » Low Profile mounting kit does not interfere with trailer floor when the chock is removed
- » Heavy duty 1" steel tubing design with vertical bracing
- » 3 sizes available to fit almost any bike
- » Black powder coated finish

Model	Chock Width
<b>MC-CH-3.5</b>	3-½ inches wide
<b>MC-CH-5.5</b>	5-½ inches wide
<b>MC-CH-6.5</b>	6-½ inches wide
<b>MC-CH Hardware</b>	Extra removable hardware packs

## SCOOTER & MOPED COVERS

Keep vespa's or scooters protected when not in use with a scooter cover. The covers are constructed of a lightweight, water resistant, polyester fabric with a scratch resistant inner lining. An elastic cord is stitched into the bottom to keep the cover tight on the scooter. Each cover is double stitched for extra durability. These scooter/vespa covers are designed for transport or storage. Three sizes available, each include a storage bag.



### FEATURES:

- » Water resistant
- » Lightweight polyester fabric material
- » Scratch resistant lining
- » Elastic cord sewn into bottom
- » Double stitched seams
- » J hook straps keep the cover secured
- » Designed for transport or storage
- » 3 universal sizes
- » Includes storage bag

Model	General Size
<b>SC-M</b>	48" Long x 22" Wide x 44" High
<b>SC-L</b>	60" Long x 32" Wide x 44" High
<b>SC-XL</b>	81" Long x 38" Wide x 55" High

## DELUXE MOTORCYCLE COVERS

Our Deluxe motorcycle covers are designed for indoor or outdoor use & are waterproof 420 denier heavy coating polyester on the top & heat resistant polyester & cotton mix on the bottom. There are 3 sizes available to fit almost any motorcycle on the road.



### FEATURES:

- » Waterproof construction designed for all climates
- » Soft interior lining on the top, heat resistant material on the bottom on the inside, Tough UV stabilized nylon exterior
- » Includes cover storage bag
- » Elastic cords at bottom for tightening
- » Attached strap to wrap cover under bike for additional moisture protection
- » Sown in grommets for security devices
- » Vents in cover to release moisture
- » Adjustable design fits bikes with accessories added
- » 3 universal sizes to fit almost every bike on the road



Model	General Size
<b>DMC-M</b>	80" Long x 44" High
<b>DMC-L</b>	94" Long x 48" High
<b>DMC-XL</b>	100" Long x 60" High x 30" Wide

## STANDARD MOTORCYCLE COVERS

The standard motorcycle cover is an economical waterproof cover with double stitched seams & has non-scratch material in the upper panel & heat resistant material in the lower panel. This cover is universal fitting & is broken down into 2 sizes. Includes a storage bag for storing when not in use.



### FEATURES:

- » Waterproof construction designed for all climates
- » Soft interior lining on the top, heat resistant material on the bottom on the inside, Tough UV stabilized nylon exterior
- » Includes cover storage bag
- » Elastic cords at bottom for tightening
- » Double stitched for durability
- » Lockable bottom
- » Adjustable design fits bikes with accessories added
- » 2 universal sizes to fit almost every bike on the road



Model	General Size
<b>MC-L</b>	94" Long x 48" High
<b>MC-XL</b>	100" Long x 60" High

# ATV PRODUCTS

## BLACK WIDOW X-TRA WIDE HEAVY DUTY FOLDING ARCHED RAMPS

The Black Widow X-tra Wide folding arched ramps are designed for loading today's current trend of larger, heavier Atv's. These ramps are 17.25" wide, fold in half & have a loading capacity of 1500 lbs. per runner.

These aluminum ramps are arched for additional clearance & will accommodate even the largest 4 or 6 wheel Atv's on the market today. These ramps also work great for loading tractors, golf carts or other wheeled equipment.

### FEATURES:

- » Fold to half their length for easy storage & transport
- » Lightweight all aluminum design w/ black powder coat
- » 3000 lb. total capacity (1500 lb. per section)
- » Arched design to increase clearance
- » Serrated cross rungs for maximum traction with 4" spacing
- » 2 heavy duty 1" wide cam buckle safety straps
- » Full width plate style attaching lip
- » Extra wide for today's larger Atv's
- » 5 year manufacturer warranty

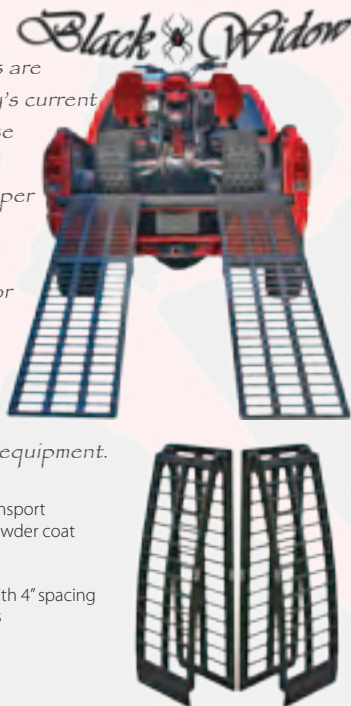

Model	Length	Width	Folded Length	Weight	Weight Capacity
<b>BW-9417-HD-2</b>	94" / 7' 10"	17.25"	48.5"	96 lbs.	3000 lbs.
<b>BW-10817-2</b>	108" / 9'	17.25"	54.5"	112 lbs.	3000 lbs.

## BLACK WIDOW FOLDING ARCHED RAMPS

The Black Widow folding arched ramps fold to half their length & adjust to fit the width of any Atv or garden tractor. These ramps are 11.25" wide, fold in half & have a loading capacity of 1200 lbs. per runner.

These aluminum ramps are arched for additional clearance & are available in 3 lengths to work with any truck or trailer height. These ramps also work great for loading small garden tractors, lawn equipment or other wheeled equipment.

### FEATURES:

- » Fold to half their length for easy storage & transport
- » Lightweight all aluminum design w/ black powder coat
- » 1200 lb. total capacity (600 lb. per section)
- » Arched design to increase clearance
- » Serrated cross rungs for maximum traction with 4" spacing
- » 2 heavy duty 1" wide cam buckle safety straps
- » Full width plate style attaching lip
- » 3 lengths available to for any loading height
- » 5 year manufacturer warranty



Model	Length	Width	Folded Length	Weight	Weight Capacity
<b>BW-9412-2</b>	94" / 7' 10"	11.25"	48.5"	44 lbs.	1200 lbs.
<b>BW-10812-2</b>	108" / 9'	11.25"	54.5"	50 lbs.	1200 lbs.
<b>BW-12012-2</b>	120" / 10'	11.25"	60.5"	54 lbs.	1200 lbs.

## ECONOMY DUAL FOLDING ALUMINUM ATV RAMPS

Our AFL series dual aluminum folding arched ramps are designed for loading Atv's & small garden tractors onto low & mid-height pick up trucks & all trailers. These economical ramps are popular among customers because they are light weight, compact, & low in cost. You will find that these light weight power houses are impossible for your customers to resist.



### FEATURES:

- » Folds in half for storage & transport
- » Lightweight All aluminum
- » Arched design to increase clearance
- » Serrated cross rungs for maximum traction
- » 2 included safety straps
- » Rubber coated fingers protect tailgate
- » 550 lb. weight capacity per ramp (1100 lb. set)
- » Economical Atv ramp system

Model	Length	Width	Folded Length	Weight	Weight Capacity
<b>AFL-9012-2</b>	90" / 7' 6"	11.25" per ramp	45"	29 lbs. (14.5 lbs. ea.)	1100 lbs. (550 lbs. per ramp)

## PLATE STYLE DUAL FOLDING ALUMINUM RAMPS

The AFP series plate style dual aluminum folding arched ramps are designed for loading Atv's & small garden tractors onto low & mid-height pick up trucks & all trailers. These ramps have a solid plate surface with a raised traction cutouts which are ideal for many loading situations where rung style ramps do not work well due to the space between the rungs like for use with smaller wheels. Because of their design these ramps are perfect for the customer who has multiple uses for a set of ramps. All aluminum design folds in half for storage.



### FEATURES:

- » Solid plate surface with raised traction cutouts
- » Folds in half for storage & transport
- » Lightweight All aluminum
- » Arched design to increase clearance
- » 2 included safety straps
- » Rubber coated fingers protect tailgate
- » 750 lb. weight capacity per ramp (1500 lb. set)

Model	Length	Width	Folded Length	Weight	Weight Capacity
<b>AFP-9012-2</b>	90" / 7' 6"	11.25" per ramp	45"	32 lbs. (16 lbs. per ramp)	1500 lbs. (750 lbs. per ramp)

### ECONOMY STEEL BI-FOLD ATV RAMP

Simple, easy, & effective. These bi-folding Atv ramps are all that's needed to load an Atv or quad into the back of your pickup truck. Constructed of 1" tubular steel, powder coated black & held together with durable steel hinges. Fold the ramp in half & it will store underneath an Atv. Rubber coated fingers protect from scratching the tailgate & secures with included safety straps. 1000 lb. total capacity.

**FEATURES:**

- » Folds to half its width
- » Ramps slide under Atv for storage
- » Strong, durable 1" steel tube construction
- » Powder coated black
- » 6.5" rung spacing
- » 2 included safety straps
- » Rubber coated fingers protect tailgate
- » 1000 lb. weight capacity

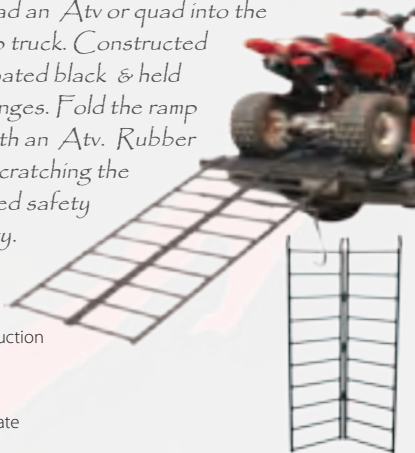

Model	Length	Width	Folded width	Weight	Weight Capacity
<b>ST-BF-7444</b>	74"/6'2"	44"	45"	36 lbs.	1000 lbs.

### LIGHT WEIGHT BI-FOLD ALUMINUM ATV RAMPS

The IBF bi-folding series of ramps fold to half their width & can be deployed in seconds. There are currently 2 styles available. The IBF-7144 is a 71" long by 44" wide lightweight bi-fold ramp with serrated circular cross bar rungs & rubber fingers.

IBF-7148 is 71" long & 48" wide for loading wider Atv's. It folds in half & has a light weight square bar cross rung design.

**FEATURES:**

- » Lightweight All aluminum
- » Folds to 1/2 its width
- » 2 included safety straps
- » Rubber coated fingers
- » 1200 lb. weight capacity
- » Serrated rungs or square rung design
- » 1 year warranty

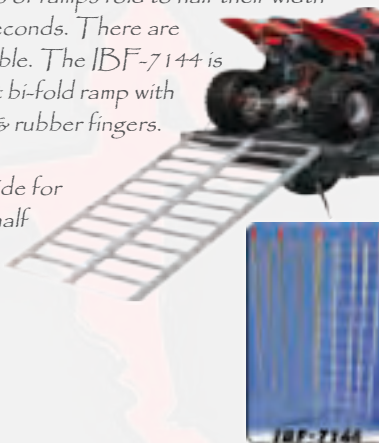

Model	Length	Width	Folded Width	Weight	Weight Capacity
<b>IBF-7144</b>	71"/ 5'-11"	44"	22"	27 lbs.	1200 lbs.
<b>IBF-7148</b>	71"/ 5'-11"	48"	24"	26 lbs.	1200 lbs.

### EXTRA LONG ALUMINUM BI-FOLD ATV RAMP

Extra-long economy style bi-fold ATV ramps, load with ease into taller trucks! Light weight, quality aluminum with a superior traction serrated cross rung system for both wet and dry use. Folds exactly in half for storage, includes rubber coated fingers and ramp safety straps.

**FEATURES:**

- » Extra long 94" length for tall / lifted trucks
- » Superior traction wet or dry with serrated cross rungs
- » Light weight aluminum construction
- » Folds exactly in half for storage
- » 1,200 lb distributed weight capacity
- » Rubber coated fingers & included safety straps
- » 1 year warranty

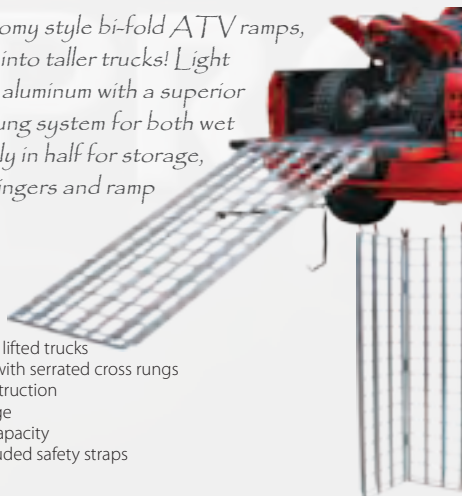

Model	Length	Width	Folded width	Weight	Weight Capacity
<b>IBF-9444</b>	94"/7'10"	44"	22"	34 lbs.	1200 lbs.

### ECONOMY STEEL BI-FOLD ATV RAMP

Designed to minimize storage space, the tri-fold Atv ramp is one of the most compact ramps available. The tri-fold ramp folds to 1/3 its size & can store under an Atv in the bed of a pickup. 1" steel tubular construction allows for a 1000 lb. weight capacity. Rubber coated ramp fingers along with 2 safety straps grip truck tailgate preventing scratches & kick out. A 6.5" rung space provides traction while lowering weight.

**FEATURES:**

- » Folds to 1/3 size to slide under Atv for storage
- » Strong 1" tubular steel construction & hinge system
- » 6.5" rung spacing
- » Powder coated black
- » 2 included safety straps
- » Rubber coated fingers protect tailgate
- » 1000 lb. weight capacity

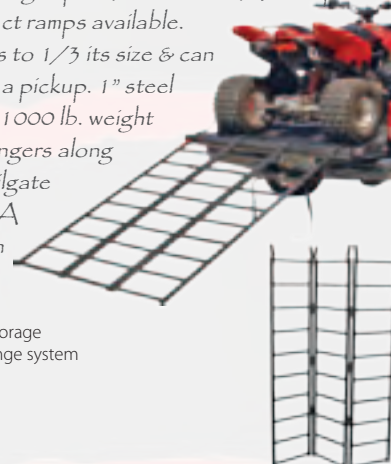

Model	Length	Width	Folded width	Weight	Weight Capacity
<b>ST-TF-7449</b>	74" / 6'2"	49"	24.5"	48 lbs.	1000 lbs.

### LIGHT WEIGHT TRI-FOLD ALUMINUM ATV RAMPS

The ITF series light weight tri-fold Atv ramps are a favorite among Atv riders. These ramps fold to 1/3rd their width & can fit between the tires of most Atv's when loaded in a pick up truck bed or on a trailer. 2 sizes of this models are available, either a 71" long by 51" wide model for loading wider Atv's onto low pick up trucks or trailers or a 46" wide by 85" long model for higher 4x4 pick up trucks. Your customers will love this design because it is light weight, compact & sets up in seconds.

**FEATURES:**

- » Lightweight All aluminum
- » Folds to 1/3rd its width
- » 2 included safety straps
- » Rubber coated fingers
- » 1200 lb. weight capacity
- » Serrated rungs for traction
- » X-tra wide to fit wider Atv's



Model	Length	Width	Folded Width	Weight	Weight Capacity
<b>ITF-7151</b>	71"/ 5'-11"	51"	17"	26 lbs.	1200 lbs.
<b>ITF-8546</b>	85"/ 7'-1"	46"	15.5"	32 lbs.	1200 lbs.

### FULL WIDTH ALUMINUM TRI-FOLD RAMP

The aluminum 46" Full Width Tri-Fold ATV ramp evenly distributes ATV weight during loading/unloading. Added traction is provided by 7" rung spacing while the entire ramp is held securely in place with four grit coated 4" support fingers and two safety straps. After use, the full width Tri-Fold ATV ramp can be triple-folded by width to 15" for convenient storage between the ATV tires.

**FEATURES:**

- » Folds to 1/3 its size
- » Ramp slides under Atv for storage
- » Rust-free all aluminum construction
- » 7" rung spacing
- » 2 included safety straps
- » Grit coated extra wide 4" fingers
- » 1250 lb. weight capacity
- » 1 year warranty

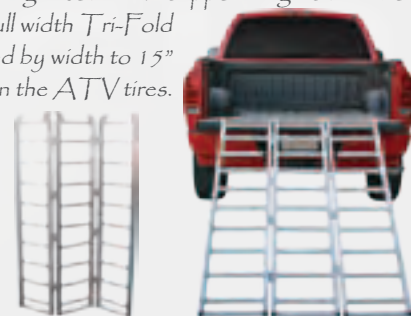

Model	Length	Width	Folded width	Weight	Weight Capacity
<b>TF-8046</b>	80"/6'8"	46"	15"	30 lbs.	1250 lbs.

**PREMIUM BI-FOLD/TRI-FOLD ATV RAMP SERIES**

These premium folding Atv ramps offer exclusive features for the customer who desires the most quality features available on an Atv ramp today. Constructed of high grade aircraft aluminum these ramps are offered in both a Tri-fold & Bi-Fold design. They have a full width plate style gripping edge instead of the standard fingers for maximum contact on the loading surface & include 2 safety straps for a superior hold. Serrated rungs at 3" spacing provides the smoothest ride available up the ramps with a top of class non-skid surface. These ramps both include an aluminum hinge system

to distribute the weight evenly to each separate section of ramp & allows them to fold to 1/2 or 1/3rd their usable width.



**FEATURES:**

- » Full width plate style gripping edge
- » Adjustable cambuckle ramp strap
- » Durable, Lightweight all aluminum
- » Serrated Rungs with 3" spacing for superior traction
- » Beveled ramp foot for maximum ground contact
- » Fold for compact storage & transport

Model	Length	Width	Folded Width	Weight	Weight Capacity
<b>TF-8248</b>	82" / 6'-10"	48"	16"	49 lbs.	1500 lbs.
<b>F-8244</b>	82" / 6'-10"	44"	22"	39 lbs.	1500 lbs.

**SNOWMOBILE RAMPS**  
FINALLY ONE LOADING RAMP TO LOAD ALL THE TOYS

Our premium snowmobile ramps are the most versatile & complete loading ramp available & make loading a snowmobile into a pickup truck or on a trailer a breeze. Designed with integrated extra slick ski guides, single, double or even triple carbides track straight & true.

The center ramp features 1/2" square cross bar cleats for maximum traction in all weather conditions and the 1250 lb capacity will load even the heaviest sleds safely. Both the center & side ramps feature a hybrid hook/plate end for strength and versatility & taper at the bottom for a smooth entry and exit. These all aluminum ramps will never rust & can be stacked neatly for storage in a truck bed or on your trailer. Additional center ramps are available for loading motorcycles, ATVs/UTVs or lawn and garden equipment.



Model	Length	Center section width	Side section width	Weight	Weight Capacity
<b>SNO-9626</b>	96" / 8'	12"	7"	39 lbs.	1250 lbs. Distributed

**HEAVY DUTY FOLDING UTV/UTILITY RAMPS**

These 10 or 12 foot long Dual Folding UTV Loading Ramps are constructed from light-weight aluminum with a serrated cross-rung system designed for maximum traction in various weather conditions. The heavy duty quality design allows for a single person to load UTVs, large ATVs, Garden Tractors, Small Farm Equipment and more! Each dual folding 14" wide UTV loading ramp can be stored at a folded 5-5/8" height, has a 12° clearance offset, and comes with a cam buckle safety. These are our heaviest duty aluminum folding ramps. Made in the USA



**FEATURES:**

- » Set includes two 14" wide ramps
- » Folds down to 5-5/8" tall
- » Offset of 12° for clearance
- » All aluminum construction
- » Serrated rungs for maximum traction
- » Includes two cam buckle safety straps
- » Up to 2,000 lb vehicle capacity with a 48" wheel base or less
- » For ATVs, UTV's, Garden Tractors, Small Farm Equipment & more!
- » 5 Year Warranty

Model	Length	Width	Folded Length	Weight (each)	Weight Capacity
<b>MF2-12014-2000-2</b>	120" / 10'	14"	60.5"	36 lbs.	2000 lbs.
<b>MF2-14414-2000-2</b>	144" / 12'	14"	72"	42 lbs.	2000 lbs.

**ALUMI-LOC RAMP LOCKING SYSTEM**

The Alumi-Loc Pro positively locks loading ramps in place for secure loading of equipment. Designed to be faster, easier to use, & more secure than straps, the Alumi-Loc Pro virtually eliminates ramp slip and can be mounted on truck beds, trailers, box trucks, containers, loading docks, or any flat surface requiring equipment loading. Works with MF2 Series motorcycle & Utv/Atv Ramps, SNO series Snowmobile Ramps & select heavy duty ramps.



**EXTRA WIDE FOLDING UTV/ GOLF CART RAMPS**

The Big Boy 2 loading ramps listed in our motorcycle catalog also can be used individually for loading Atv's, golf carts, UTV's, zero turn lawn mowers or just about any pneumatic wheel vehicle up to 2500 lbs.! Each section is 19" wide & is constructed of lightweight aluminum & can be connected together with (4) included connecting brackets for loading motorcycles. The ramp system can be folded in half at the center for storage, & when unfolded, features a 12° offset for greater clearance for lower vehicles. For Specifications see the Big Boy2 in the Motorcycle Ramp section of the catalog.



# LAWN & GARDEN RAMPS

## LIGHT WEIGHT FOLDING DUAL RAMPS

These ramps were built for quality, ease of use & compact size. The SF-9012 are 12 inches wide each & fold to half their length for compact storage in a truck bed, truck cab or under a quad. Lightweight all aluminum construction & a convenient carrying handle make for easy transporting. A slight arch & 90" of length allows loading a 4 wheeler into all 2 wheel drive & most standard height 4x4 trucks. For garden tractors with low deck clearance, a longer arch ramp may be necessary for high 4x4 trucks.

### FEATURES:

- » Built in carry handle to carry like a suitcase
- » Slight arch helps preventing in bottoming out or scraping of machinery
- » Serrated Rungs at 3" spacing for a smooth, non-skid ride up
- » Full width attaching lip for maximum tailgate contact
- » Lightweight all aluminum construction
- » Hinge system allows ramps to fold exactly in half
- » 1500 lb. load capacity



Model	Length	Width	Folded Length	Weight	Weight Capacity
<b>SF-9012</b>	90" / 7'-6"	12"	46"	44 lbs.	1500 lbs.

## STRAIGHT ALUMINUM TRAILER RAMPS

Made of ultra light, rust proof T6 aluminum, Straight Aluminum Trailer Ramps are specifically designed to give small-wheeled motor vehicles increased traction in a variety of weather conditions with the unique serrated rung system. A solid plate on the end of each ramp ensures a flush fit to most trailers and the included safety straps keep the ramps secure during use. Each pair of Straight Aluminum Ramps are rated to a maximum capacity of 2,000 lbs.

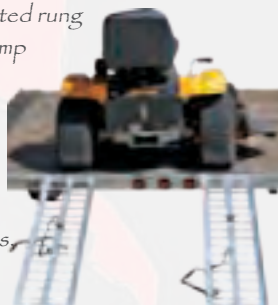

Model	Length	Width	Weight (each)	Weight Capacity
<b>S-4816-2000-2</b>	48" / 4'	16"	12.5 lbs.	2000 lbs.
<b>S-6012-2000-2</b>	60" / 5'	12"	42 lbs.	2000 lbs.

## ALUMINUM TRACTOR SHED RAMPS

These small but useful ramps were manufactured after numerous customer request. Measuring 3' long these ramps are designed for garden tractors & small wheeled equipment to allow them to get up small rises such as garden sheds, curbs, medians, even some low trailers. A total of 1500 lb. capacity, a 4" long full width attaching lip, 4" rung spacing are a few of the quality features on this popular little powerhouse.

### FEATURES:

- » All aluminum Construction
- » Serrated Rungs at 4" spacing
- » 4" long Full attaching lip with pin hole
- » Lightweight all aluminum construction
- » Weigh only 8 lbs. & easily hang on wall
- » 1500 lb. load capacity

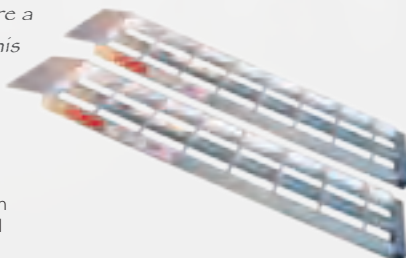

Model	Length	Width	Thickness	Weight	Weight Capacity
<b>S-368-1500</b>	36" / 3'	8"	1.5"	8 lbs.	1500 lbs. (750 ea.)

## ARCHED ALUMINUM RAMPS

We have a large selection of dual arched ramps for loading Atvs, garden tractors, golf carts or other 4 wheeled equipment. We have short models for trailers & longer models for higher loading jobs. The advantage of dual ramps is they can adjust to the width of any 4 wheeled vehicle wheel base & they take up less room than full width ramps.

Arched ramps allow additional clearance while loading into a pick up truck or trailer. We hold a patent on our style of arched ramps & they are loaded with quality features that allow these ramps to sell themselves when they are sitting on your showroom floor. We also have folding arched ramps which can be seen in our Atv Section.

### FEATURES: (on all but IA-9012 economy model)

- » Full width plate style gripping edge has a durable 3MTM rubber adhered to protect your tail gate or other loading surfaces for a solid & safe hold
- » Arch helps prevent bottoming out or scraping of machinery
- » Serrated Rungs at a spacing of 3" exhibits a non skid surface second to none
- » 1.5 inch raised ramp edges that act like curbing to keep you on the tires in the track
- » Adjustable safety cables to ensure a safe loading experience (3' length)
- » Durable all aluminum (T6 - 6061) construction will provide for many years of non-rusting safe use
- » Can be custom made to any length required



Model	Length	Width	Weight	Weight Capacity
<b>A-7214-2000-2</b>	72" or 6'	14"	28 lbs.	2000 lbs.
<b>A-8412-1200-2</b>	84" or 7'	12"	30 lbs.	1200 lbs.
<b>A-8416-3000-2</b>	84" or 7'	16"	44 lbs.	3000 lbs.
<b>IA-9012-2</b>	89" or 7'-5"	12"	28 lbs.	1200 lbs.
<b>A-8912-1800-2</b>	89" or 7'-5"	12"	35 lbs.	1800 lbs.
<b>A-9512-1200-2</b>	95" or 7'-11"	12"	37 lbs.	1200 lbs.
<b>A-9516-3000-2</b>	95" or 7'-11"	16"	48 lbs.	3000 lbs.

# ATV BASKETS, BOXES & ACCESSORIES

## FRONT/ REAR ATV RACK BASKETS

Atv rack baskets are designed to hold extra gear on a Atv utilizing the front & rear racks. The baskets mount to most tubular Atv racks & includes mounting hardware. The baskets are constructed of steel for durability & have mesh sides & bottom to allow dirt or debris to fall right through. Includes a 1 year warranty not including rust from scratching & outdoor use

### FEATURES:

- » Rear & Front baskets available
- » Self cleaning mesh sides & bottom
- » Steel construction
- » Universal mounting hardware



Model	Rack Use	Size	Weight
<b>FB-2020</b>	Front Racks	17"L x 36"W x 6.5"H	28 lbs.
<b>ODB-2010</b>	Front Racks	26.75"L x 41"W x 12.75"H	42 lbs.

## ATV RACK PACKS

Available in Camo or Black, these durable Atv rack packs hold extra gear or cargo on rear Atv racks. The fabric is 600D polyester which is water proof & tough enough to withstand the wear of off road riding. Each pack has 4 straps to secure to a rack. 2 designs are available with or without a padded cushion. Inside the packs are velcro secured dividers for separating gear. 3200 cubic inches of storage space.

### FEATURES:

- » Designed to fit on Atv rear racks
- » Constructed of 600D polyester
- » Velcro storage dividers
- » (4) securing straps
- » Waterproof - Camouflage & Black colors
- » 3200 cubic inches of storage space



Model	Description	Storage Capacity
<b>62101</b>	Atv Rear Rack Pack w/o cushion Color: Black	3200 cubic inches (33" x 16" x 9")
<b>62201</b>	Atv Rear Rack Pack w/o cushion Color: Camo	3200 cubic inches (33" x 16" x 9")
<b>62102</b>	Atv Rear Rack Pack w/ cushion Color: Black	3200 cubic inches (33" x 16" x 11")
<b>62202</b>	Atv Rear Rack Pack w/ cushion Color: Camo	3200 cubic inches (33" x 16" x 11")
<b>62103</b>	Atv Front or Rear Rack Pack Color: Black - Rectangular Shape	4572 cubic inches (33" x 16" x 9")

## ATV COVERS

Atv covers for protection from dirt, dust or weather. Made from 100% waterproof polyester which is UV & mildew resistant with double stitched seams for durability. The bottom has an elastic cords sewn in with quick release buckles & straps to keep the cover. Camo or olive drab available.

### FEATURES:

- » Waterproof Polyester Construction
- » UV/ mildew resistant
- » Velcro storage dividers
- » Elastic bottom cord
- » Quick release buckles & straps
- » Double stitched seams
- » Available in medium or large / camo or olive drab



Model	Description	Color
<b>ATV-OM</b>	82" x 48" x 31.5"	Olive Drab
<b>ATV-OL</b>	87" x 49" x 33.5"	Olive Drab
<b>ATV-CM</b>	82" x 48" x 31.5"	Camouflage
<b>ATV-CL</b>	87" x 49" x 33.5"	Camouflage

## STANDARD ATV CARGO BOX

The standard Atv cargo box is designed for hauling extra cargo on the rear rack of an Atv. The box is constructed of high density polyethylene & features a padded backrest. Mounting the cargo box to the Atv rack requires drilling into the bottom of the box & attaching with included U shaped bolts. The cargo box is lockable & has a rear reflectors for added visibility.

### FEATURES:

- » Lockable
- » Durable high density polyethylene shell
- » Backrest cushion
- » Mounts with U bolts ( drilling required )



Model	Inner Dimensions	Outer Dimensions	Weight
<b>ATV-CB-8010</b>	9.75"L x 30.25"W x 13"H	20"L x 34"W x 13.5"H	20 lbs.

## DELUXE ATV CARGO BOX

The deluxe Atv cargo box is designed for transporting extra gear or cargo on the rear rack of an Atv. The cargo box features a soft foam padded backrest & inside straps for holding extra gear. The box has 2 handles on the top for setting up or moving. Velcro straps keep the box secure to the Atv rack with optional U bolts for permanent mounting ( drilling required ). The rear of the box features reflective tape for added visibility.

### FEATURES:

- » Durable high density polyethylene shell
- » Lockable
- » Foam cushion Backrest cushion
- » Mounts with U bolts ( drilling required )



Model	Inner Dimensions	Outer Dimensions	Weight
<b>ATV-CB-8020</b>	12-17"L x 34.5"W x 8.5-13"H	21.5"L x 37.5"W x 15.5"H	22 lbs.

## ATV RACK PACKS

Atv fender & tanks bags are constructed of 600D polyester fabric with durable zipper closures. Each fender & tank bag is available in black or camouflage & features 2 (or more) pockets for storing extra items. Fender packs have integrated securing straps which universally attach to the rear or front fender of an Atv. Tank saddle bags attach via the gas tank cap.

### FEATURES:

- » Designed to fit on ATV gas tanks & rear or front fenders
- » Constructed of 600D polyester fabric
- » Mesh & lined pockets
- » Securing straps attach to ATV
- » Waterproof
- » Camouflage or Black available

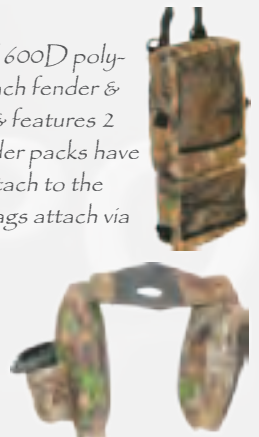

Model	Description	Storage Capacity
<b>62104</b>	Atv Gas Tank Saddle Bag Color: Black	2 pockets- 1 mesh pocket- 1 cup holder w/ draw string
<b>62204</b>	Atv Gas Tank Saddle Bag Color: Camo	2 pockets- 1 mesh pocket- 1 cup holder w/ draw string
<b>62107</b>	Atv Fender Pack Color: Black	2 lined pockets
<b>62207</b>	Atv Fender Pack Color: Camo	2 lined pockets 2 mesh pockets
<b>62108</b>	Atv Tank Bag Color: Black	2 lined pockets 2 mesh pockets



# CARGO PRODUCTS

## BLACK WIDOW BASKET CARGO CARRIER

The Black Widow hitch mounted cargo basket is a high quality hitch mounted cargo carrier that fits into any class III two inch receiver. The Carrier has a black epoxy powder coated finish & a 350 lb. capacity. It measures 50" long x 20" wide x 6" high.

### FEATURES:

- » Heavy Duty black epoxy powder coating
- » 500 lb. weight capacity
- » Mesh traction surface
- » 5 inch raised tubular side rails
- » Steel tubular construction
- » Fits in any 2" trailer hitch opening



Model	Length	Width	Rail Height	Weight	Weight Capacity
<b>BW-5020</b>	50"	20"	6"	34 lbs.	500 lbs.

## ROOF CROSS BARS

Our most economical roof Cross Bars fits most factory raised rails & is ready to use out of the box & easy to install with no tools required. Galvanized & black powder coating for corrosion resistance, adjusts to 50" wide & holds up to 130 lbs.



Model	Max Width	Rail Requirements	Weight	Weight Capacity
<b>LB-2301</b>	50"	Rail width 41" apart up to 1-3/4" diameter	4 lbs.	130 lbs.

## DELUXE ROOF CROSS BARS

The upgraded LB-8303 roof Bars fits most factory raised rails & includes locking caps & keys to protect from theft. Ready to use out of the box & easy install with no tools required. PE tube wrapped for elegant look & better corrosion resistance. Adjusts to 50" wide & holds up to 130 lbs.



Model	Max Width	Rail Requirements	Weight	Weight Capacity
<b>LB-8303</b>	50"	Rail width 41" apart up to 1-3/4" diameter	4 lbs.	130 lbs.

## FOLDING WHEEL STEP

This folding wheel step allows easy access to the roof rack of a vehicle & quickly folds flat for compact storage under a seat. Adjusts to fit any tire up to a 22" rim.

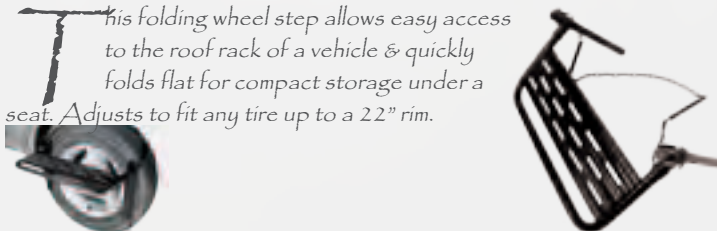

Model	Requirements	Weight	Capacity
<b>AA-7624</b>	Fits on any tire up to 22" rim	3 lbs.	220 lbs.

## BLACK WIDOW ROOF CARGO BASKET

The Black Widow roof basket cargo carrier mounts to existing roof cross bars like those found on most Suv's & mini-vans today. This roof rack comes with a heavy duty black epoxy powder coated finish & measures 42"x39"x4.5" tall. An optional extension is also available which adds 20" in length to this roof rack.

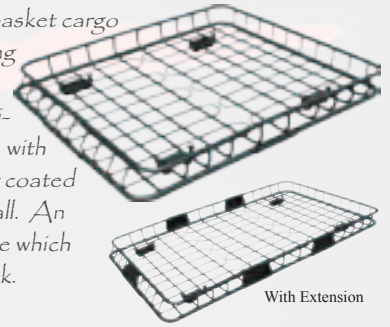

Model	Length	Width	Rail Height	Weight	Weight Capacity
<b>RB-DLX</b>	42"	39"	4.5"	18 lbs.	200 lbs.
<b>RB-DLX-EXT</b>	20"	39"	4.5"	7 lbs.	200 lbs.
<b>RB-DLX-FRG</b>	n/a	38"	n/a	1 lbs.	n/a

## ECONOMY ROOF CARGO RACK

The ER-04206 roof cargo rack mounts to existing roof cross bars like those found on most Suv's & mini-vans today. This roof rack comes with a heavy duty black epoxy powder coated finish. This rack offers a quality design for the budget conscious. Ships broken down for minimum shipping costs, assembly is required.

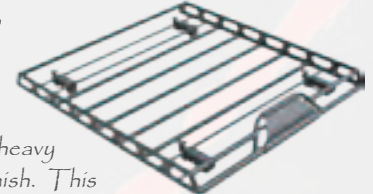

Model	Length	Width	Rail Height	Weight	Weight Capacity
<b>ER-02406</b>	39.5"	36"	2.75"	14 lbs.	200 lbs.

## DELUXE ROOF CARGO BASKET

The ER-08208 Deluxe roof basket cargo carrier mounts to existing roof cross bars like those found on most Suv's & mini-vans today. This stylish roof rack comes with a heavy duty black epoxy powder coated finish & measures 42"x39"x4.5" tall & includes all mounting hardware for cross bars, or us our LB-02301 cross Bars.



Model	Length	Width	Rail Height	Weight	Weight Capacity
<b>ER-08208</b>	45.25"	30.25"	5"	25 lbs.	200 lbs.
<b>ER-08208-F</b>	n/a	30.25"	n/a	1 lbs.	n/a

11.5 CU.FT. WATERPROOF SOFT SIDE CAR TOP CARRIERS

Add extra cargo storage to a vehicle with the RBG-02 soft side car top carrier created from a weatherproof heavy duty PVC nylon. The car top carrier features a storm flap, self-repairing zipper & tie down straps, designed to mount to an existing vehicle's roof rack.

**FEATURES:**

- » Mounts to a vehicle roof rack
- » Storm Flap
- » Self-Repairing Zipper
- » Waterproof PVC Coated Nylon
- » Easy to fold soft sides
- » 1 Year Warranty



Model	Description	Dimensions	Cubic Ft. Capacity
<b>RBG-02</b>	Soft Side Car Top Carrier	37" x 30" x 18"	11.5 cuft.

15 CU.FT. WATERPROOF SOFT SIDE CAR TOP CARRIERS

The weatherproof soft-sided car top carrier ties down to an existing vehicle roof rack for added vehicle cargo storage. Created from heavy duty PVC nylon, each car top carrier features a self-repairing zipper, a storm flap & adjustable tie down straps.

**FEATURES:**

- » Mounts to a vehicle roof rack
- » Storm Flap
- » Self-Repairing Zipper
- » Waterproof PVC Coated Nylon
- » Easy to fold soft sides
- » 1 Year Warranty



Model	Description	Dimensions	Cubic Ft. Capacity
<b>RBG-01</b>	Soft Side Car Top Carrier	38" x 38" x 18"	15 cuft.

14.8 CU.FT. WATERPROOF SOFT SIDE CAR TOP CARRIERS

Designed for larger cargo, the RBG-06 will hold up to 14.8 cubic feet on a vehicle roof rack with the included tie-down straps, in a weatherproof heavy duty PVC coated nylon. Each large capacity car top carrier bag features a self-repairing zipper & water resistant flap cover.

**FEATURES:**

- » Mounts to a vehicle roof rack
- » Storm Flap
- » Self-Repairing Zipper
- » Waterproof PVC Coated Nylon
- » Large Capacity, easy to fold soft sides
- » 1 Year Warranty



Model	Description	Dimensions	Cubic Ft. Capacity
<b>RBG-06</b>	Soft Side Car Top Carrier	43" x 35" x 17"	14.8 cuft.

XL CAPACITY CARGO CARRIER & ROOF CARRIER COMBO

When even more extra cargo space is needed, the extra large RBG-04 is fit for the challenge. The waterproof cargo bag can be mounted to a vehicle roof rack or cargo carrier with the included rack tie-down straps. Whether its stored on the roof rack or on a cargo carrier, the flap cover, self-repairing zipper, & PVC nylon coat are sure to keep gear dry during transportation.

**FEATURES:**

- » Mounts to a vehicle roof rack
- » Storm Flap
- » Self-Repairing Zipper
- » Waterproof PVC Coated Nylon
- » Extra Large, easy to fold soft sides
- » 1 Year Warranty



Model	Description	Dimensions	Cubic Ft. Capacity
<b>RBG-04</b>	XL Cargo Bag for Roof or Hitch Carrier	59" x 24" x 24"	19.6 cuft.

14.26 CU.FT. CAR TOP ROOF BAG

The car top roof bag is designed with heavy duty flexible PVC coated nylon, a self-repairing zipper, & a weatherproof flap to transport a variety of differently or odd shaped cargo. Each car top roof bag mounts to a vehicle roof rack with the included tie down straps.

**FEATURES:**

- » Mounts to a vehicle roof rack
- » Storm Flap
- » Self-Repairing Zipper
- » Waterproof PVC Coated Nylon
- » Easy to fold soft sides for oddly shaped cargo
- » 1 Year Warranty



Model	Description	Dimensions	Cubic Ft. Capacity
<b>RBG-05</b>	Car Top Roof Bag	38" x 38" x 18"	14.26 cuft.

WATERPROOF ROLLING ROOF TOP LUGGAGE CARRIER

With smooth rolling polyurethane wheels & a pull-style handle, Rolling Car Top Luggage can be stored on an existing vehicle roof rack with the provided tie-down straps, then removed & rolled to the destination without needing to lug individual contents or the entire bag. Rolling Car Top Luggage allows for easy cargo transportation & features a steel reinforced framework, an inline zipper/velcro pocket & two 8' tie down straps.

**FEATURES:**

- » Mounts to a vehicle roof rack
- » Storm Flap & Self-Repairing Zipper
- » Waterproof PVC Coated Nylon
- » Easy rolling polyurethane wheels
- » Built-in Pull style handle
- » Extra zippered, velcro pocket
- » 1 Year Warranty



Model	Description	Dimensions	Cubic Ft. Capacity
<b>RBG-03</b>	Rolling Car Top Luggage	34" x 16" x 14"	4.5 cuft.

### HITCH MOUNTED CARGO CARRIERS

Tray style cargo carriers mount to 2" receiver hitches and have a thick steel mesh bottom with a strong flat plate 2.75" side rail construction. The side rails provide up to 12 unique tie-down points and can be extended 8 inches with an optional kit. Two tray style cargo carrier versions are available, one folding and the other non-folding. The folding version pivots up and out of the way when needed. Each tray style cargo carrier comes with reflective strips for safety and are designed with a maximum weight capacity of 500 pounds.



**FEATURES:**

- » Steel construction for superior strength
- » 500 lb capacity
- » Thicker steel mesh bottom
- » 2.75" side rails keep your gear secure
- » 12 tie down points
- » Black powder coat finish
- » Assembles with simple hand tools
- » 1 year warranty



Model	Usable Length	Usable Width	Weight Capacity
<b>NON-FOLDING CARGO CARRIERS</b>			
<b>CC-4820</b>	19.25"	47.75"	500 lbs
<b>CC-6020</b>	19.25"	59.75"	500 lbs
<b>FOLD UP CARGO CARRIERS</b>			
<b>CC-F4820</b>	19.25"	47.75"	500 lbs
<b>CC-F6020</b>	19.25"	59.75"	500 lbs

### HITCH MOUNTED BASKET CARGO CARRIERS

Folding and non-folding cargo baskets use a vehicle hitch to provide extra cargo space. The folding basket has a pull-pin design allowing the basket to be folded up and out of the way. Both versions are constructed from steel for superior strength and have a thick mesh bottom with sturdy 5-1/2" side rails for multiple tie-downs and gear protection. Reflective strips are included for safety purposes in low-light conditions. These 500 lb capacity cargo baskets feature versatile ways of transporting extra cargo and can be used with cargo nets and some cargo bags.



**FEATURES:**

- » Steel construction for superior strength
- » 500 lb capacity
- » Thicker steel mesh bottom
- » Taller 5.5" side rails keep your gear secure
- » Black powder coat finish
- » Assembles with simple hand tools in minutes
- » 1 Year Warranty
- » Fits all 2" receivers
- » Hitch pin required (sold separately)
- » Folding and non-folding styles available

Model	Usable Length	Usable Width	Weight Capacity
<b>NON-FOLDING CARGO CARRIERS</b>			
<b>CCB-4820</b>	17.75"	46.75"	500 lbs
<b>CCB-6020</b>	17.75"	58.75"	500 lbs
<b>FOLD UP CARGO CARRIERS</b>			
<b>CCB-F4820</b>	17.75"	46.75"	500 lbs
<b>CCB-F6020</b>	17.75"	58.75"	500 lbs

### UNIVERSAL PICK UP TRUCK RACK

Transport and haul ladders, pipes, lumber and more with the innovative pickup truck cargo solution, a Titan Universal Truck Rack. Specifically designed to support up to 850 lbs and maintain access to anything stored in the truck bed below. The entire cargo rack is adjustable to fit a variety of truck bed sizes and features multiple tie-down points for a variety of cargo options.



**FEATURES:**

- » Zinc coated hardware and an all steel construction
- » Black Powder Coat Finish
- » Universal Mount Design for Full and Mid-sized pick-up trucks
- » Multiple Tie-Down Points
- » Cab-overhang to protect the vehicle roof
- » Designed for hauling ladders, lumber and pipes
- » Carries up to 850 lbs
- » 1 Year Warranty



Model	Dimensions	Weight	Weight Capacity
<b>UPUT-RACK</b>	132"L x 57"W x 32" H	145 lbs.	850 lbs.

### ROOFTOP BIKE RACK & GEAR BAG COMBO

The SP1 is a roof mounted bike rack that also has an integrated UV & water resistant 1.5 cu. ft. bag. Fits on aftermarket roof bars & easily installs or removes in seconds. Rear adjustable tire holder fits all sizes & has aluminum fork mounts that fit up to two bicycles.



**FEATURES:**

- » Transport 2 bicycles & extra gear
- » Wheel cradles with integrated straps
- » Fork mount design
- » Cargo bag is removable
- » Black powder coated finish



Model	Bike Capacity	Bag Capacity
<b>SP1</b>	2	1.5 cu.ft.

# PREMIUM BIKE RACKS/CARRIERS

## EAGLE 2+2 TOWING 4 BIKE CARRIER

The Eagle 2+2 includes a unique bike frame locking clamp system that rotates to safely support various kinds of bikes & converts from a 2 to a 4 bike carrier with the included extension. The hitch bar extends out with a reinforced opening to mount a tow ball which allows towing up to a 2000 lb. trailer.

The Eagle includes 2 keys & a 80" steel construction with black powder coat finish.



### FEATURES:

- » Allows for towing a trailer
- » Holds 2 or 4 bicycles
- » Lockable for bicycle security
- » All Steel Construction
- » Swings down for rear door access
- » Black powder coated finish

Model	Bike Capacity	Hitch Size	Weight Capacity
<b>BC-EGL-2+2</b>	2 or 4	2"	120 lbs.

## 2+2 BIKE PLATFORM 4 BICYCLE CARRIER

This bike rack takes our platform bike rack design to the next level. The removable rack extension turns the 2 bike rack into a 4 bike carrier so the user can change the capacity of the rack to meet their hauling needs. The bike tires easily fit into the platforms that adjusts from 50-76" long & each bike has a attaching bar with rubber coated grips that fits on the frame. This rack both folds up when not loaded & folds down to access a rear hatch or door or tailgate. All steel construction with black powder coat finish.

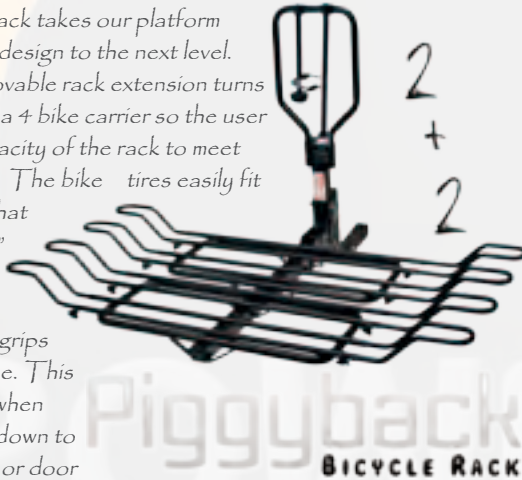

### FEATURES:

- » Transport 2 or 4 bicycles
- » Adjustable wheel cradles with attaching bars
- » Folds up vertical when not in use
- » Folds down for rear vehicle access
- » All Steel Construction
- » Black powder coated finish



Model	Bike Capacity	Hitch Size	Weight Capacity
<b>BC-08581-2A+2EXT</b>	2 or 4	2"	120 lbs.

## 3+2 LOCKING 5 BIKE CARRIER

The 3+2 bike rack converts from a 3 to a 5 bike carrier with the included extension for versatility while traveling. Rubber frame mounting pads protect the bicycle frame while in use & lock for bike security & includes 2 keys. Folds down to access a rear hatch or door or tailgate. All steel construction with black powder coat finish.



### FEATURES:

- » Lockable for bicycle security
- » Transport 3 or 5 bicycles
- » Rubber cradle mounts protect bike frame finish
- » Folds down for rear vehicle access
- » All Steel Construction
- » Black powder coated finish

Model	Bike Capacity	Hitch Size	Weight Capacity
<b>BC-08816-3A+2EXT</b>	3 or 5	2"	150 lbs.

## 3 BIKE PLATFORM BICYCLE CARRIER

This innovative 3 bike rack is full of quality features that set it apart from others. The bike tires easily fit into 1 of 3 platforms that adjusts from 50-76" long & each bike has a attaching bar with rubber coated grips that fits on the frame. This rack both folds up when not loaded & folds down to access a rear hatch or door or tailgate. All steel construction with black powder coat finish.



Model	Bike Capacity	Hitch Size	Weight Capacity
<b>BC-3581</b>	3	2"	100 lbs.

### 3 BIKE TIRE MOUNT RACK FOR 1.25 OR 2" HITCH

Haul up to 3 bicycles with this tilting tire mounted carrier rack designed to work with either 1-1/4" Class II or 2" Class III/IV receiver hitches. A unique tire-well configuration straps bicycle tires in place on the platform while a 26" support and 360° grasp locks bicycle frames in place with extra tie-down points. The entire 3 mount bicycle carrier rack is also able to tilt down as far as 90° for unrestricted access to a SUV hatch. Great for Mountain Bikes with large frames.



#### FEATURES:

- » Designed to transport up to 3 large bicycles
- » Integrated tie-down strap system
- » 360° arm with a 360° swivel clamp
- » Works with 1-1/4" and 2" hitch receivers
- » Dark Gray Powder Coat Finish
- » Two protective foam rests
- » Easy to turn knobs for adjustments
- » 90° tilt mechanism for trunk & hatch access
- » 1 Year Warranty

Model	Bike Cap.	Hitch Size	Weight Cap.
<b>BC-9584-3A</b>	3	1.25 or 2"	100 lbs.

### 4+1 SWING DOWN 5 BIKE CARRIER

This 4 bike rack features a unique adaptor allowing to carry an additional bicycle on the rack giving it a 5 bicycle capacity. Bike frames rest on the plastic cradles and are secured to the carrier with adjustable rubber straps. The fork arms can be folded down to accommodate small space when not in use. The rack post can be folded down away from the vehicle for access to the rear hatch of a vehicle without removing the carrier. Includes a hitch extension adaptor.

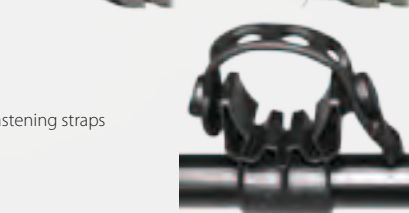

#### FEATURES:

- » Includes hitch extender
- » Transport 4 or 5 bicycles
- » Plastic frame cradles with rubber fastening straps
- » Folds down for rear vehicle access
- » All Steel Construction
- » Black powder coated finish
- » Includes a hitch pinch bolt

Model	Bike Cap.	Hitch Size	Weight Cap.
<b>BC-8815-4AH+1EXT</b>	4 or 5	1.25 or 2"	100 lbs.

### TRUNK OR HATCHBACK 2-BIKE TIRE MOUNT RACK

SUV and cars are able to transport 1 or 2 bikes without a receiver hitch by mounting the Buzz Rack Skipper to a trunk or hatch. The Skipper is height adjustable for maintaining license plate and tail light visibility while driving and features two 180° pivot points allowing the rack to be mounted to most vehicles. Includes safety straps, protective foam padding and adjustable wheel mounts. Great for Mountain Bikes with large frames.



#### FEATURES:

- » Hauls 1 or 2 Bicycles
- » Uses a 6 point tie strap system for hatch and trunk attachment
- » Four protective foam bumpers
- » Height adjustable ensuring license plate and tail light visibility
- » Black powder coat finish
- » Center support for added stability
- » Two 180° pivot points
- » Lock-nut assembly system
- » Includes all necessary tie-down and safety straps
- » 1 Year Warranty

Model	Bike Capacity	Weight Capacity
<b>BC-9524-2P</b>	2	70 lbs.

### 2+1 SWING DOWN 3 BIKE CARRIER

The 2+1 bicycle carrier features a unique 1 bike add on that allows the carrier to transform from a 2 bike to a 3 bike carrier. The carrier swings down for rear door access & the arms fold down when not in use. An included receiver adaptor is included allowing the carrier to be used on a 1.25 or 2" receiver. Includes a hitch pin bolt to remove slack in the receiver



#### FEATURES:

- » Transport 2 or 3 bicycles
- » Folds down for rear vehicle access
- » All Steel Construction
- » Black powder coated finish
- » Can be used on 1.25 or 2" receiver hitches with included adaptor
- » Plastic frame cradles with rubber fastening straps
- » Includes hitch pinch bolt

Model	Bike Cap.	Hitch Size	Weight Cap.
<b>BC-8812-2AH+1A+1EXT</b>	2 or 3	1.25 or 2"	100 lbs.



# BICYCLE RACKS/CARRIERS

## 3 BIKE TRUNK MOUNTED BICYCLE CARRIER

The BC-7510-3 is the most economical of our trunk bicycle carriers. This model has durable coated arms that hold 3 bikes & foam cushions to protect the vehicle. Comes with black powder coat finish. Fits trunks, hatchbacks, suv's & most vans & folds for compact storage.



Model	Bike Capacity	Weight Capacity
<b>BC-7510-3</b>	3	100 lbs.

## 3 BIKE HATCHBACK BICYCLE CARRIER

The BC-7513-3H designed with the hatchback of vans & Suv's in mind but also works on a trunk mount application. This model has adjustable cradles for 3 bikes for a better hold, 6 straps for a stronger tie down & foam cushions to protect the vehicle. Designed to allow licence plate to be visible at all times. Comes with black powder coat finish. Fits hatchbacks on suv's & most vans & trunks & folds for compact storage.

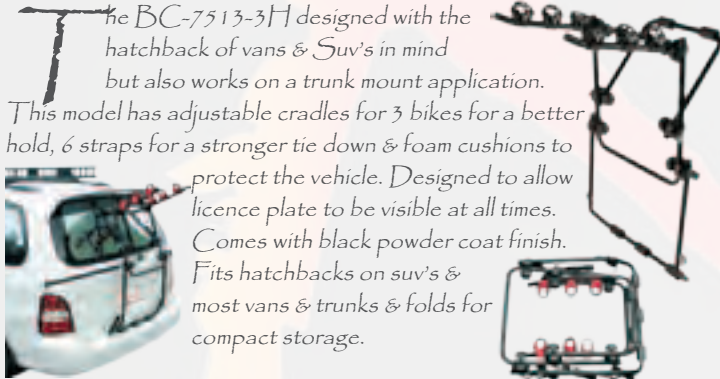

Model	Bike Capacity	Weight Capacity
<b>BC-7513-3H</b>	3	100 lbs.

## DELUXE FOLD DOWN 3 BIKE CARRIER

The HMBC-4808 is a deluxe 3 bike carrier with many high quality features but offered at an affordable price. The rubber coated bike clamps include a key locked turn down knob to protect the bikes from theft & a reflector for safety. Locking pin & a release lever allow the carrier to quickly fold down to access the rear hatch back or trunk. A rubber coated bike stop prevents bikes from getting too close to the vehicle. Comes with black powder coat finish & includes hitch pin with 2 mounting positions.



Model	Bike Capacity	Hitch Size	Weight Capacity
<b>HMBC-4808</b>	3	2"	100 lbs.

## ALTERNATIVE BIKE ADAPTOR

This adjustable length adaptor fits women's, children's or Y-frame bicycles to allow them to fit onto bicycle racks & carriers. Push button opening loops are plastic to protect the bike frame. Black powder coat finish.

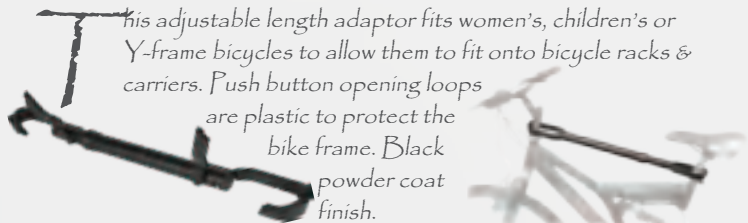

Model	Length	Weight Capacity
<b>AA-8602</b>	3	45 lbs.

## 3 BIKE REAR HATCH BICYCLE CARRIER

The BC-7509-3 trunk bicycle carriers has extra foam added to offer better protection to the bike tubes, holds 3 bikes & has foam cushions to protect the vehicle. Comes with black powder coat finish. Fits trunks, hatchbacks, suv's & most vans & folds for compact storage.



Model	Bike Capacity	Weight Capacity
<b>BC-7509-3</b>	3	100 lbs.

## DELUXE 3 BIKE TRUNK MOUNTED BIKE CARRIER

The BC-7518-3H is our top end trunk bike rack. This model has adjustable cradles for 3 bikes with integrated soft pads, 6 straps for a stronger tie down & foam cushions to protect the vehicle. Folds up & has a quick release system for easier opening. Comes with black powder coat finish. Fits hatchbacks on suv's & most vans & trunks.

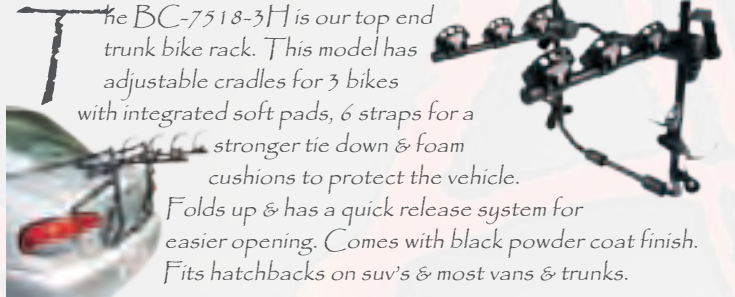

Model	Bike Capacity	Weight Capacity
<b>BC-7518-3H</b>	3	100 lbs.

## 3 BIKE SPARE TIRE BIKE RACK

The BC-2525 is designed to fit on a spare tire mounted on the rear of a vehicle either in the middle or offset. Universal, adjustable design fits spare tires from 7-10" wide. Rubber coated arms hold 2 bikes & swing down when not in use. Comes with black powder coat finish, tie down straps & no assembly required.. Fits hatchbacks on suv's & most vans & trunks & folds for compact storage.

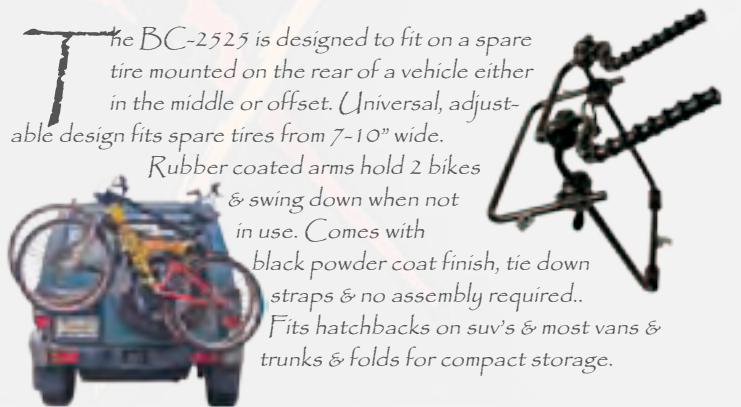

Model	Bike Capacity	Weight Capacity
<b>BC-2525</b>	2	65 lbs.

## 3 BIKE HITCH GRIP TOWING RACK

This unique bike carrier wraps around a 2" hitch bar receiver allowing the user to still use the full capacity of the receiver hitch & ball when towing. This model has adjustable cradles for 3 bikes & the arms fold down when not in use. Comes with black powder coat finish & folds up for compact storage. Includes locking hitch pin & a 2" tube for when not using a receiver.

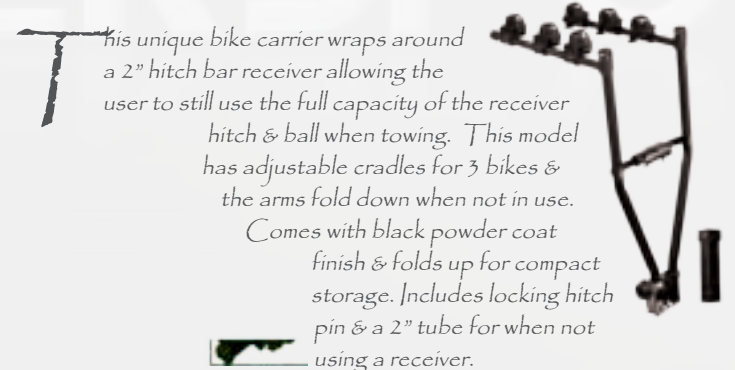

Model	Bike Capacity	Hitch Size	Weight Capacity
<b>TMBC-4567</b>	3	2"	100 lbs.

# PET PRODUCTS

## ALUMINUM FOLDING DOG RAMPS

Aluminum folding dog ramps are designed to aid pets in reaching raised surfaces such as into vehicles or up stairs. The ramps are portable with the ability to fold in half with a carrying handle on the side for easy maneuvering. 3 different lengths are available for specific applications. The folding dog ramps are constructed of aluminum making them light-weight & rust proof.



### FEATURES:

- » Aluminum construction with grip tape surface
- » Folding design for portability
- » Integrated carrying handle on the side
- » Integrated strap keeps ramp folded together
- » 3 lengths available

Model	Length	Width	Folded Length	Weight	Weight Capacity
<b>DR-06</b>	72" / 6'	15"	36"	18 lbs.	250 lbs.
<b>DR-07</b>	82" / 6'10"	15"	41"	20 lbs.	250 lbs.
<b>DR-08</b>	96" / 8'	15"	48"	26 lbs.	250 lbs.

## EXTRA WIDE ALUMINUM FOLDING DOG RAMPS

Extra wide aluminum folding dog ramps are designed to aid pets in reaching raised surfaces such as into vehicles or up stairs. The ramps are portable with the ability to fold in half with a carrying handle on the side for easy maneuvering. 3 different lengths are available for specific applications. The folding dog ramps are constructed of aluminum making them light-weight & rust proof. Extra wide design for larger dogs.



### FEATURES:

- » Aluminum construction with grip tape surface
- » 18.75" wide to allow more stability for larger pets
- » Folding design for portability
- » Integrated carrying handle on the side
- » Integrated strap keeps ramp folded together
- » 3 lengths available

Model	Length	Width	Folded Length	Weight	Weight Capacity
<b>DR-06-XW</b>	72" / 6'	18.75"	36"	21 lbs.	250 lbs.
<b>DR-07-XW</b>	82" / 6'10"	18.75"	41"	23 lbs.	250 lbs.
<b>DR-08-XW</b>	96" / 8'	18.75"	48"	28 lbs.	250 lbs.

## STANDARD VEHICLE PET BARRIER

The standard pet barrier is designed to fit into SUV's or cars to prevent pets from becoming potential distractions while driving. These pet barriers have 4 width adjusting bars & 2 height adjusting legs. 4 cupped ends grip the roof & floor of the vehicle keeping the pet barrier stable.



### FEATURES:

- » Universal fitting
- » Cup ends grip floor & roof for stability
- » 4 width-wise adjustable bars
- » 2 height-wise adjustable legs

Model	Adjustable Width	Adjustable Height
<b>DB-2704</b>	33.5" - 57"	34" - 50"

## DELUXE VEHICLE PET BARRIER

The deluxe pet barrier is designed to fit into SUV's or cars to prevent pets from becoming potential distractions while driving. These pet barriers have 6 width adjusting bars & 2 height adjusting legs. 4 cupped ends grip the roof & floor of the vehicle keeping the pet barrier stable.

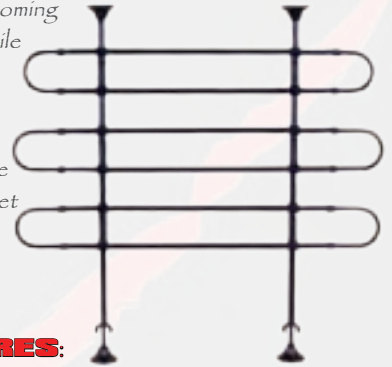

### FEATURES:

- » Universal fitting
- » Cup ends grip floor & roof for stability
- » 6 width-wise adjustable bars
- » 2 height-wise adjustable legs

Model	Adjustable Width	Adjustable Height
<b>DB-2706</b>	33.75" - 57"	35" - 50"

## 8 BAR VEHICLE PET BARRIER

The 8 bar pet barrier is designed to fit into SUV's, vans, or cars to prevent pets from becoming potential distractions while driving. These pet barriers have 8 width adjusting bars & 2 height adjusting legs. 4 cupped ends grip the roof & floor of the vehicle keeping the pet barrier stable.

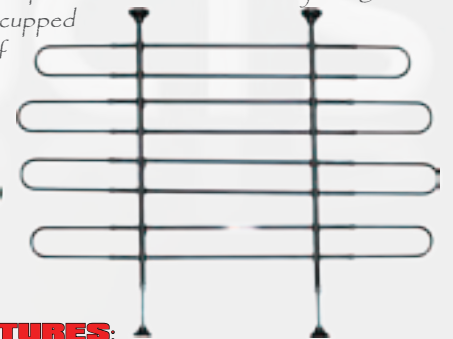

### FEATURES:

- » Universal fitting
- » Cup ends grip floor & roof for stability
- » 8 width-wise adjustable bars
- » 2 height-wise adjustable legs

Model	Adjustable Width	Adjustable Height
<b>DB-2708</b>	35.25" - 62"	36.75" - 52"

### MESH VEHICLE PET BARRIER

The mesh pet barrier is designed to fit in compacts, midsize SUV's, & most crossovers. The barrier is constructed of steel wire mesh with 2 adjustable sides & 2 adjustable legs. Polyurethane cups on the top & bottom grip the roof & floor of the vehicle for a stable hold.

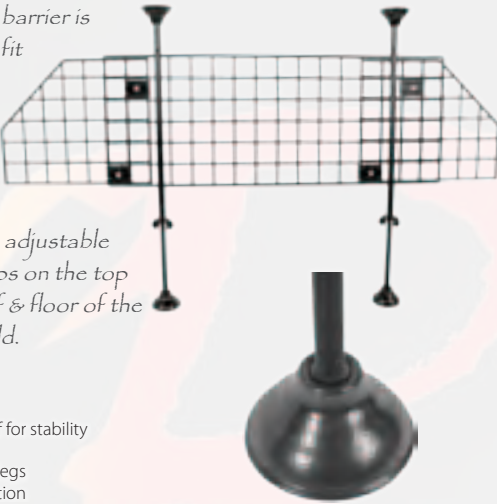

**FEATURES:**

- » Adjustable fitting
- » Cup ends grip floor & roof for stability
- » 2 adjustable mesh sides
- » 2 height-wise adjustable legs
- » Steel wire mesh construction

Model	Adjustable Width	Adjustable Height
<b>DB-3722</b>	34" - 55.25"	23" - 43"

### DELUXE MESH VEHICLE PET BARRIER

The deluxe mesh pet barrier is designed to fit in full size SUV's, minivans, & some wagons. The barrier is constructed of steel wire mesh with 2 adjustable sides & 2 adjustable legs. Polyurethane feet & mesh top covering grip the roof & floor of the vehicle for a stable hold.



**FEATURES:**

- » Adjustable fitting
- » Cup ends grip floor & roof for stability
- » 2 adjustable mesh sides
- » 2 height-wise adjustable legs
- » Steel wire mesh construction

Model	Adjustable Width	Adjustable Height
<b>DB-03721-S</b>	36" - 59"	24" - 43.25"

### BUCKET SEAT VEHICLE PET BARRIER

The bucket seat pet barrier is designed to be used in cars, SUV's, & vans for keeping pets out of the front drivers area. The barrier has an adjustable center bar with a polyurethane cup end to secure in between bucket seats. Constructed of durable steel tubing with an epoxy powder coating.

**FEATURES:**

- » Adjustable fitting
- » Cup end grips roof for stability
- » 2 adjustable mesh sides
- » Steel tube construction

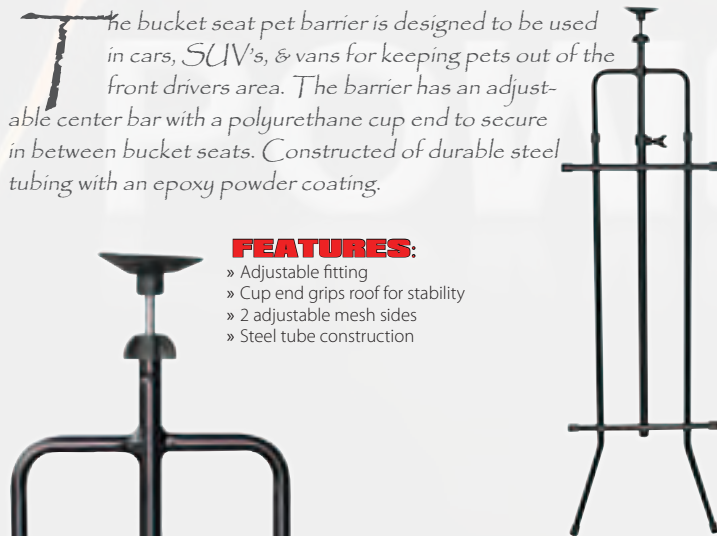

Model	Width	Adjustable Height
<b>DB-3716</b>	12"	39" - 48"

### ANGLED PET BARRIER

The angled pet barrier is designed to fit into SUV's or cars with reclined seats to prevent pets from becoming potential distractions while driving. These pet barriers have 4 width adjusting bars & 2 height adjusting legs. 4 cupped ends grip the roof & floor of the vehicle keeping the pet barrier stable.

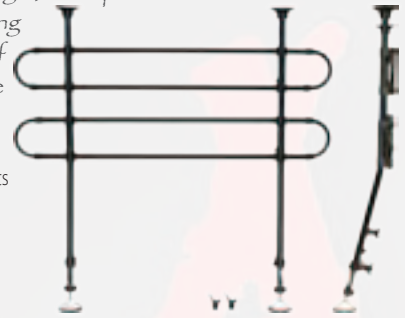

**FEATURES:**

- » Angled to fit vehicles with reclined seats
- » Cup ends grip floor & roof for stability
- » 4 width-wise adjustable bars
- » 2 height-wise adjustable legs

Model	Adjustable Width	Adjustable Height
<b>DB-2702</b>	33.5" - 60"	29.5" - 40"

### INDOOR CANVAS PET GATE

The canvas indoor pet gate is designed to keep pets in or out of rooms in the home. The gate features a heavy duty durable canvas covering with a steel tubular framing. 4 end cups grip the door jam or wall opening. The pet gate is adjustable to fit openings up to 42" wide. Quick, easy setup & removal for moving from room to room.

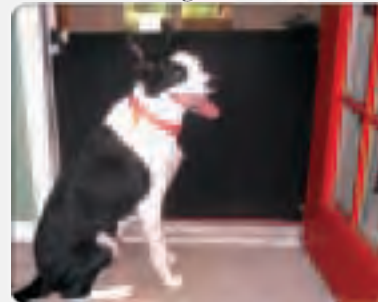

**FEATURES:**

- » Adjustable width up to 42"
- » Cup ends grip door jams or walls
- » Heavy duty durable canvas covering
- » Strong steel frame

Model	Adjustable Width	Height	Color
<b>DB-7737-BLK</b>	31" - 42"	30"	<b>Black</b>
<b>DB-7737-TAN</b>	31" - 42"	30"	<b>Brown</b>

MORE INNOVATIVE  
PET PRODUCTS  
COMING IN MID 2010

VISIT [www.RAGEPOWERSPORTS.COM](http://www.RAGEPOWERSPORTS.COM)  
FOR UPDATED & NEW PRODUCT INFO



# HEAVY DUTY RAMPS

## 72" CAR TRAILER RAMPS

Our 72" car trailer ramps have a 2500 lb. weight capacity per axle (vehicles up to 4500 lbs.) for loading of car trailers, farm equipment or construction equipment. These all aluminum ramps are light weight & will never rust even being kept outside. They are available with a plate end or hook end to attach to most car trailers. These ramps have a wide, serrated cross rung for superior traction.



### FEATURES:

- » 2 available ramp ends, hook or plate
- » Extra wide serrated cross bar for tractions & a smooth ride
- » Light Weight All Aluminum Construction
- » Store flat on top of each other
- » 2500 lb. per axle rating (4500 lb. total vehicle weight)
- » 2 included safety straps



**HOOK END      PLATE END**



Model	Length	Width	Thickness	Weight (each)	End	Weight Capacity
<b>TR-72-H</b>	72"/ 6'	12"	2"	19 lbs.	Hook	2500 lbs. per axle
<b>TR-72-P</b>	72"/ 6'	12"	2"	19 lbs.	Plate	2500 lbs. per axle

## SUPER DUTY TRAILER RAMPS

These Super Heavy Duty trailer ramps have either a 8000 or 10,000 lb. weight capacity per axle for loading of large commercial equipment or farm equipment. These all aluminum ramps are light weight and will never rust & are available in 2 lengths for varying trailer heights. These ramps are a hefty 14" or 16" wide & are available only with a hook end to attach to most trailers. These ramps have wide, serrated cross rungs for superior traction.



### FEATURES:

- » Heavy duty hook end to attach to trailer rails
- » Extra wide serrated cross bar for tractions & a smooth ride
- » 2 lengths to choose from
- » Light Weight All Aluminum Construction
- » Store flat on top of each other
- » 8000 or 10,000 lb. capacities available
- » Serrated foot for stable connection with ground
- » 2 included safety straps

Model	Length	Width	Thickness	Weight (each)	End	Weight Capacity
<b>TR-90</b>	90"/ 7' - 6"	14"	4.25"	47 lbs.	Hook	10,000 lbs. per axle
<b>TR-168</b>	168"/ 14'	16"	6.25"	96 lbs.	Hook	8000 lbs. per axle

## 5000 LB. TRAILER RAMPS

These Heavy Duty trailer ramps have a 5000 lb. weight capacity per axle (vehicles up to 8500 lbs.) for loading of cars, farm equipment & heavy machinery. These all aluminum ramps are light weight & will never rust & are available in 2 lengths for varying trailer heights. These ramps are a hefty 14" or 16" wide & are available with a plate end or hook end to attach to most trailers. These ramps have a wide, serrated cross rung for superior traction.



### FEATURES:

- » 2 available ramp ends, hook or plate
- » 2 lengths to choose from
- » Extra wide serrated cross bar for tractions & a smooth ride
- » Light Weight All Aluminum Construction
- » Store flat on top of each other
- » 5000 lb. per axle rating (8500 lb. total vehicle weight)
- » Serrated foot for stable connection with ground
- » 2 included safety straps

Model	Length	Width	Thickness	Weight (each)	End	Weight Capacity
<b>TR-94-H</b>	94"/ 7' - 10"	14"	3.25"	35 lbs.	Hook	5000 lbs. per axle
<b>TR-94-P</b>	72"/ 7' - 10"	14"	3.25"	35 lbs.	Plate	5000 lbs. per axle
<b>TR-120-H</b>	120"/ 10'	16"	4.75"	47 lbs.	Hook	5000 lbs. per axle
<b>TR-120-P</b>	120"/ 10'	16"	4.75"	47 lbs.	Plate	5000 lbs. per axle

## SEMI TRUCK WHEEL RISERS

Lightweight, all aluminum wheel risers have a huge 20,000 lb. capacity & only weigh 48 lbs. each for portability. The surface of the heavy duty wheel risers is made of cross bar plates with a serrated traction surface. The service ramps are 64" long allowing for use with lower clearance trucks. These service ramps can be used with semi trucks, RV's, or other heavy duty pneumatic wheeled vehicles.



### FEATURES:

- » Durable aluminum construction wont rust
- » 20,000 lb capacity
- » Serrated traction surface
- » Portable for road side repairs
- » For single or dual wheels



Model	Length	Lifting Height	Width	Weight	Weight Capacity
<b>WR-7K</b>	63"	9.5"	16"	32 lbs. per ramp	7000 lbs. (per axle)
<b>WR-20K</b>	64"	9.5"	16"	48 lbs. per ramp	20,000 lbs. (per axle)

**LOW PROFILE CAR SERVICE RAMPS**

The Mini-Lift car ramps are designed to do what most standard car ramps cannot, lift lower clearance vehicles like many of today's sports cars. 2 models to choose from for most vehicle sizes. No more trying to struggle getting a hydraulic jack under a lowered vehicle for service or scraping the front clip of a lowered car with standard car ramps. Raise even the lowest of vehicles with our "ML-1066". All aluminum construction & a 3000 lb load capacity (1500 lbs ea.) All aluminum constructions means they are light weight & will never rust.



**FEATURES:**

- » All aluminum construction provides a light weight car ramp that never rusts
- » The extended length works great for lowered sports cars that would bottom out on most standard car ramps.
- » Raises a vehicle 10 inches & have built in tire stops
- » Serrated rungs on the center section at a spacing of 3" & have a non skid surface second to none

Model	Length	Width	Height	Weight	Weight Capacity
<b>ML-1066</b>	66"	14"	10"	50 lbs. (25 lbs. ea.)	3000 lbs. (1500 per ramp)

**LOW PROFILE SERVICE RAMPS**

Safely get your car off the ground 9.5 inches for repair, service or show. 74" removable ramps secure onto each platform to get even low profile vehicles up in the air easily which is perfect for low profile sports cars. Once on the platforms the ramps can be removed allowing extra work space under the vehicle.

These all aluminum vehicle ramps feature sturdy construction & a serrated rung surface to provide excellent traction for even muddy or wet tires. A stable platform base & wheel stops at the end of the platform helps reduce the risk of driving off the end of the platform.



**FEATURES:**

- » 3000 lb max axle capacity
- » Extra large 24 x 16 platform with tire stop
- » Super long 73.75" detachable ramps
- » Tall 9.5" lift height
- » Lowest loading angle available - 7.6 degrees
- » Lightweight high quality aircraft aluminum
- » Serrated rung surface provides excellent traction



Model	Platform Length	Platform Height	width	Weight	Weight Capacity
<b>CR-7214</b>	16"	9.5"	10"	42 lbs. ea.	3000 lbs. (per axle)

**BUS SERVICE STANDS**

Bus service stands are designed for raising the wheels of buses or large commercial vehicles for service & maintenance. The ramps are modular in design & can be taken apart. Each ramp section has its own carrying handle & weighs no more than 50 lbs. The surface of these service ramps features a serrated cross plate design for traction. The bottom of the stands feature a commercial grade PVC belted rubber bonded on to keep the ramps from sliding. Constructed of aluminum making them lightweight & rust proof.



**FEATURES:**

- » Durable aluminum construction wont rust
- » 48,500 lb capacity
- » Serrated traction surface
- » Commercial grade PVC belted rubber bonded to underside
- » Ramps break down into sections with carrying handles weighing no more than 50 lbs.
- » For tandem axles or single axles

Model	Length	Height	Width	Weight	Weight Capacity
<b>Bus stands-Front (Single Axles)</b>	117"	6.5"	20.5"	145 lbs. Per Ramp	48,500 lbs. (per ramp)
<b>Bus stands-Rear (Tandem Axles)</b>	154"	6.5"	20.5"	200 lbs. Per Ramp	48,500 lbs. (per ramp)

**CUSTOM HEAVY DUTY RAMPS**

Rage Powersport's manufacturing division can manufacture custom heavy duty ramps or other products for many specific applications based on you or your customers needs. If you need ramps for a specific trailer type, vehicle type or other application, we can build ramps for almost every application.

We have the manufacturing capability to make almost any product out of aluminum or steel and be able to substantially cut your manufacturing costs and allow you to focus on marketing your products. We currently supply custom made products to trailer companies, Auto manufacturers, transportation companies and the U.S. Military. In house engineering allows us to quickly manufacture custom ramps from 1000 -20,000 lb. capacity and beyond and an almost limitless number of custom machined products.





The origins of Rage Powersports started way back in 1993 as Lite Products in Crane Missouri. Lite Products was an aluminum loading ramp manufacturer with several patents on ramps and other products they manufactured. As the business evolved and grew our core goal was to offer the most innovative, highest quality loading, hauling and transporting cargo products available.

Today, our lineup of products is one of the most diversified in the industry and are available in the US and Canada at fine retailers that serve the Powersports, Heavy Duty Equipment, Mobility, Pet and Bicycle markets.

Looking forward, we will continue to diversify and expand our product lines with dependable, quality built, profitable products that give our dealers an advantage over their competition. Please check our website often as we continually have new product in development and additional products that are not included in this catalog.

We look forward to serving your needs.

